

700 SERIES SHOP MANUAL

SECTION 21

**ATTACHMENTS**

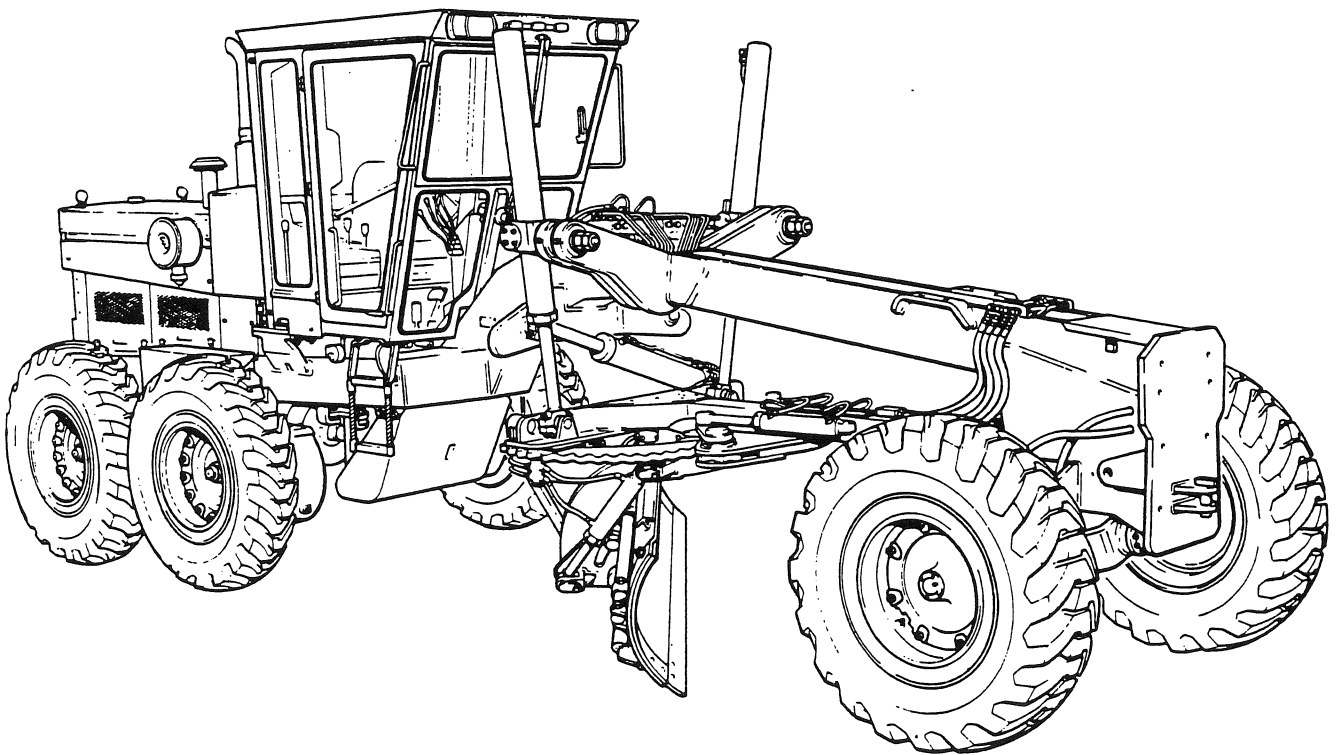



ATTACHMENTS  
DISASSEMBLY AND ASSEMBLY INSTRUCTIONS

GENERAL

Before starting to disassemble or assemble any of the attachments, ensure that suitable lifting tackle and adequate tools are available. Ensure that precautions are taken to prevent dust and dirt entering the hydraulic system when hoses and tubes are disconnected or re-connected (refer to Service Bulletin No. 284).

Refer to Section 19 for details concerning the overhaul of the attachment hydraulic circuits.

When ordering replacement parts, reference should be made to the spare parts manual.

NOTE:

All weights, measures and tolerances are quoted in both Imperial and Metric figures. Following the internationally accepted standard, the decimal point is denoted by a comma in all Metric measurements.

SCARIFIER

1. Removal and Disassembly (Fig. 1).

WARNING:

Before disconnecting any hydraulic hoses or fittings, remove the wedges (24) and tooth shanks (26); then lower the scarifier onto the ground.

The scarifier hydraulic circuit is normally connected to the right hand side of the manifold valve either directly, or through a manually operated selector valve if a front mounted attachment is installed.

NOTE:

On certain machines not equipped with moldboard power tilt, the extreme left hydraulic control valve is used.

2. If the scarifier cylinder is not to be removed, no action on the hydraulic circuit is required. However, if the

scarifier cylinder is to be removed, it will be necessary to disconnect the hoses from the fittings on the grader frame nose side plates.

3. After identifying each hose with its corresponding fitting to ensure correct assembly, disconnect the hoses from the frame and cylinder. Plug the open ports.
4. Remove the two hexagon head bolts (8), pal nuts (36) and nuts (37) retaining each ball cap (6). Swing both lift link assemblies onto the ground, and remove the ball cap shims (38).
5. Attach suitable lifting tackle to both drawbars (43). Remove the capscrews (40) and lockwashers (41) retaining the draw pin keepers (42). Remove the two draw pins (39). Drive the grader ahead to disconnect the drawbars from the lugs.
6. Remove the two hexagon head bolts (28), pal nuts (33) and nuts (32) retaining each ball cap (29). Remove the two lift links (34) and ball cap shims (31).
7. Remove the bolt (35), nut (20) and lockwasher (19). Remove the lower ball stud (30), nut (23), lockwasher (22) and flatwasher (21). Lower the drawbar onto the ground.
8. Repeat step 7, preceding, for the other drawbar. Remove the drawbars and scarifier box assembly (25) away from the grader.
9. Remove the hexagon head bolt (5), nut (13) and lockwasher (14) retaining the piston rod to the arm assembly. Remove the hexagon head bolt (1), nut (4) and lockwasher (3) retaining the cylinder (2) to the frame. Remove the cylinder.
10. Remove the two nuts (18) and lockwashers (17) securing each U-bolt (11). Remove the U-bolts and pillow block upper halves (9).
11. Remove the arm assembly. Remove the pillow block lower halves (16), together with the pillow block shims (15).

ATTACHMENTS

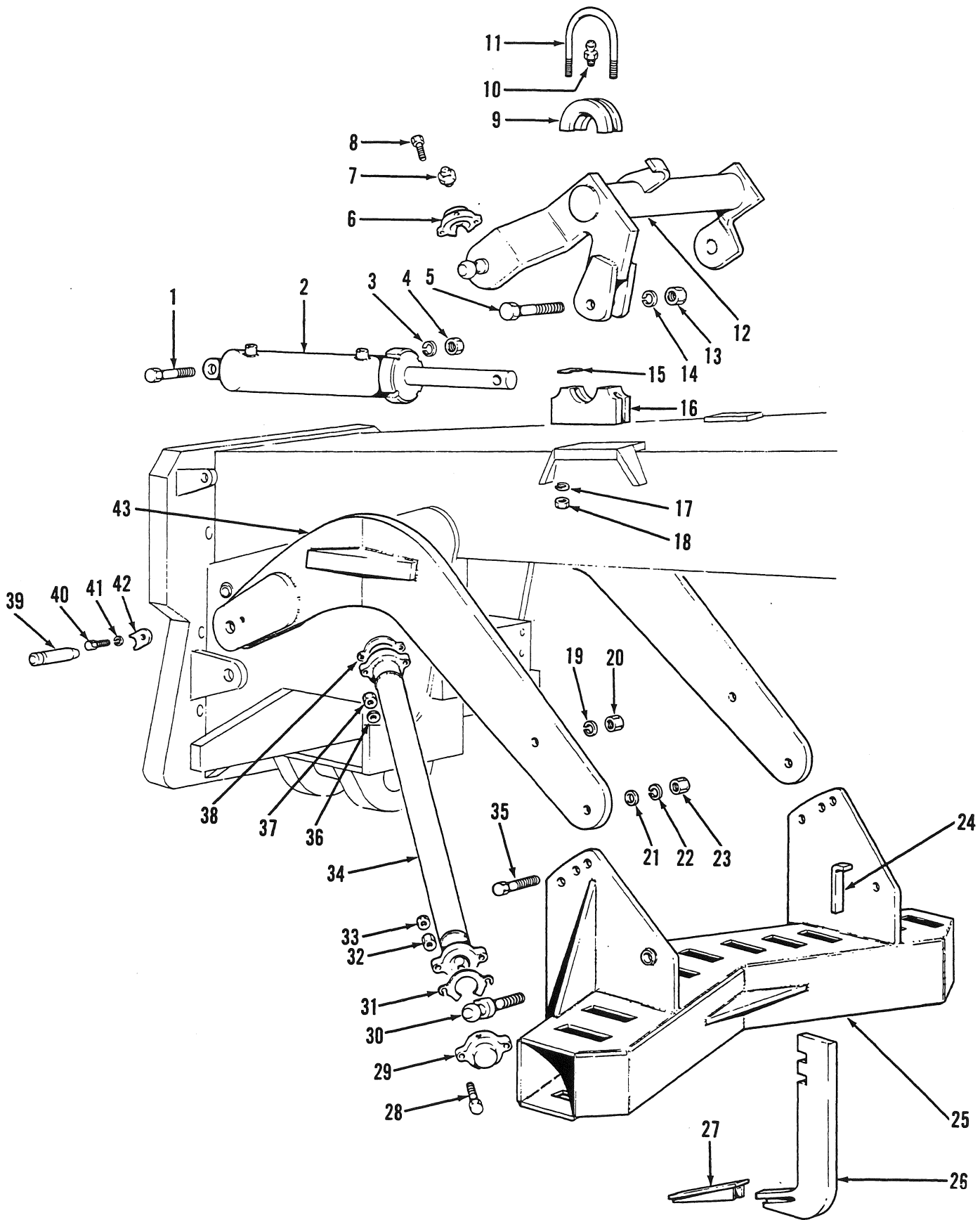

Figure 1

ATTACHMENTS

REF. NO.	DESCRIPTION	REF. NO.	DESCRIPTION
1	3" LG. HEX. BOLT	23	NUT
2	CYLINDER	24	WEDGE
3	LOCKWASHER	25	BOX ASSY.
4	NUT	26	TOOTH SHANK
5	3" LG. HEX. BOLT	27	TOOTH TIP
6	BALL CAP	28	2 1/2" LG. HEX. BOLT
7	1/8" STRAIGHT GREASE FITTING	29	BALL CAP
8	2 1/2" LG. HEX. BOLT	30	LOWER BALL STUD
9	PILLOW BLOCK (UPPER HALF)	31	SHIM - BALL CAP
10	1/8" STRAIGHT GREASE FITTING	32	NUT
11	U-BOLT	33	PAL NUT
12	ARM ASSY.	34	LIFT LINK
13	NUT	35	3" LG. HEX. BOLT
14	LOCKWASHER	36	PAL NUT
15	SHIM - PILLOW BLOCK	37	NUT
16	PILLOW BLOCK (LOWER HALF)	38	SHIM - BALL CAP
17	LOCKWASHER	39	DRAW PIN
18	NUT	40	3/8" LG. HEX. CAPSCREW
19	LOCKWASHER	41	LOCKWASHER
20	NUT	42	DRAW PIN KEEPER
21	FLATWASHER	43	DRAWBAR
22	LOCKWASHER		

KEY TO FIG. 1

NOTE:

Additional reinforcing has been incorporated on the drawbars and box assembly -effective serial number 9840. Refer to Service Bulletin No. 291. Also, a travel stop was introduced commencing at serial number 10035. Refer to Service Bulletin No. 296.

12. Assembly and Installation (Fig. 1). Using suitable lifting tackle, hoist the scarifier box assembly (25) and position under the grader frame neck.
13. Using a chain hoist, install the two drawbars (43), and retain to the scarifier box side plates with the hexagon head bolts (35), nuts (20) and lockwashers (19). Install the lower ball studs (30), nuts (23), lockwashers (22) and flatwasher (21). DO NOT tighten the hardware yet.
14. With the aid of the lifting tackle, maneuver the scarifier assembly until the clevis of the drawbars engage with the lugs on the nose plate. Install the two draw pins (39), tapered end first.
15. Liberally apply grease onto the bearing surfaces of the two pillow block lower halves (16). Place the pillow block lower halves into position on their brackets.
16. Install the arm assembly onto the pillow block lower halves. Install the pillow block shims (15) (six per block).
17. Liberally apply grease onto the bearing surfaces of the two pillow block upper halves (9). Install the pillow block upper halves, and secure with the U-bolts (11), nuts (18) and lockwashers (17).
18. Liberally apply grease onto the bearing surfaces of the ball caps (6 and 29), and to the mating parts of the two lift links (34).
19. Install the ball cap shims (38), and engage the lift link with the ball stud on the arm assembly. Install the ball cap and retain with the two hexagon head bolts (8), nuts (37) and pal nuts (36). Repeat this step for the other lift link.
20. Install the ball cap shims (31), and engage the lift link with the ball stud on the scarifier box assembly. Install the ball cap and retain with the two hexagon head bolts (28), nuts (32) and pal nuts (33). Repeat this step for the other lift link.
21. Using suitable lifting tackle, raise and lower the scarifier assembly to determine if there is any presence of binding at the ball studs and pillow blocks. If any binding occurs, add shims as necessary. Tighten all hardware.

## ATTACHMENTS

22. Hoist the cylinder (2) in position, and engage the clevis of the cylinder with the lug on the nose plate. Retain the cylinder barrel with the hexagon head bolt (1), nut (4) and lockwasher (3). Retain the piston rod with the hexagon head bolt (5), nut (13) and lockwasher (14).
23. Install the draw pin keeper (42), and retain with the hexagon head capscrew (40) and lockwasher (41).  

NOTE:  
For new drawbars, it may be necessary to re-tap the 3/8 inch hole.
24. Re-connect the hydraulic hoses to the frame and cylinder, ensuring that each hose is connected to its corresponding fitting.
25. Install the tooth shanks (26), and retain with the wedges (24). Remove the lifting tackle.
26. Adjustments (Figs. 1 and 2). The pitch of the scarifier (1, Fig. 2) can be adjusted by removing the hexagon head bolts (35, Fig. 1), nuts (20, Fig. 1) and lockwashers (19, Fig. 1), aligning the drawbars with an alternative hole, and replacing the hardware.
27. For tooth working depth adjustment (2, Fig. 2), remove the wedges (24, Fig. 1) and move the tooth shank (26, Fig. 1) to an alternative notch engagement; then replace the wedges.
28. Worn tooth tips (27, Fig. 1) can be removed by drifting on the tip rear face (3, Fig. 2). Install new tips onto the shanks, and drive into position.

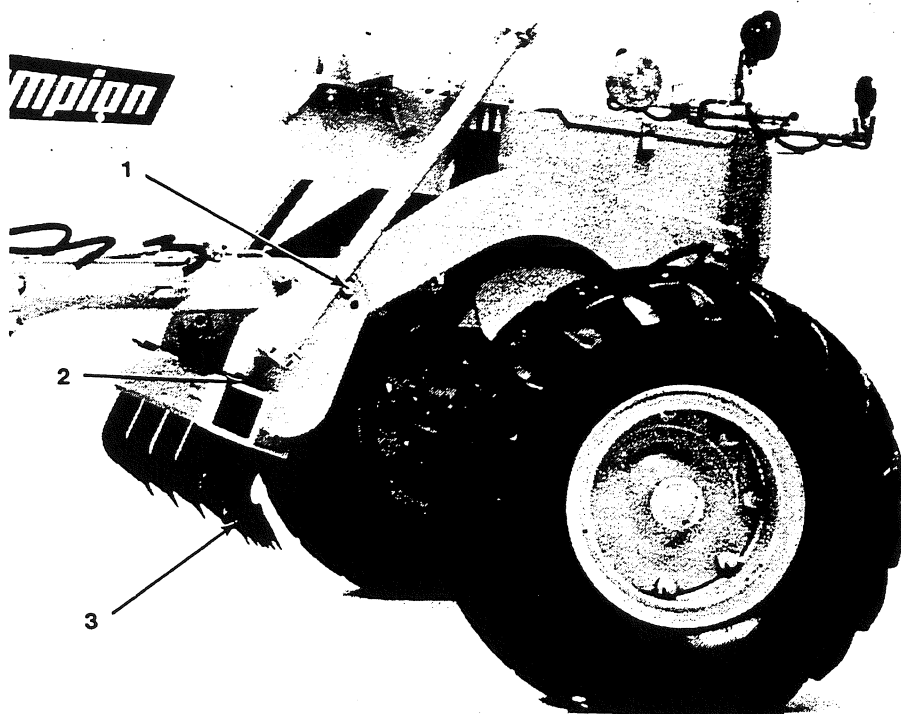

Figure 2

## ATTACHMENTS

### BULLDOZER

#### 1. Removal and Disassembly (Fig. 3).

WARNING:

Before disconnecting any hydraulic hoses or fittings, lower the bulldozer blade onto the ground.

The bulldozer hydraulic circuit is connected to the right hand side of the manifold valve either directly, or through a manually operated selector valve if a scarifier is installed.

2. If the bulldozer cylinder is not to be removed, no action on the hydraulic circuit is required. However, if the bulldozer cylinder is to be removed, it will be necessary to disconnect the hoses from the fittings on the grader nose side plates.
3. After identifying each hose with its corresponding fitting to ensure correct assembly, disconnect the hoses from the frame and cylinder. Plug the open ports.
4. Attach suitable lifting tackle to the bulldozer blade (1, 8 or 10). Remove the klipring fasteners (24 and 25) securing the pins (19 and 22) connecting the upper push arms (2) to the bulldozer blade and the yokes (13 and 14). Remove the pins and upper push arms.
5. Remove the klipring fasteners (25) securing the three pins (22) connecting the push frame (3) to the bulldozer blade. Remove the pins. Hoist the bulldozer blade away from the grader.
6. Remove the klipring fasteners (23) securing the two pins (17 and 18) connecting the lift link (6) to the push frame and yoke (5). Remove the pins and lift link.
7. Remove the klipring fasteners (24) securing the two pins (20) connecting the push frame to the A-frame (7). Remove the pins and the push frame.
8. Attach suitable lifting tackle to the yoke (5). Remove the klipring fasteners (23) securing the two pins (16 and 18) connecting the cylinder (12) to the A-frame and yoke. Remove the pins and cylinder.
9. Arrange the hoist in such a way that the lifting tackle will support the weight of the A-frame. Remove the four hexagon head bolts (30, 31 or 32), nuts

(34) and lockwashers (33) retaining the left hand yoke (14) and right hand yoke (13). Remove the yokes and shims (15).

#### 10. WARNING:

Ensure that the A-frame is securely attached to the lifting tackle.

Remove the four hexagon head bolts (29), nuts (34) and lockwashers (33). Lower the A-frame onto the ground. Remove the two klipring fasteners (24) securing the pin (21). Remove the pin and yoke. Hoist the A-frame away from the grader. Remove the lifting tackle.

11. Assembly and Installation (Fig. 3). Install the yoke (5) onto the A-frame (7), and retain with the pin (21). Secure the pin with two kliprings (24).
12. Attach suitable lifting tackle to the yoke. Hoist the yoke and A-frame into position on the grader nose plate. Install four hexagon head bolts (29), nuts (34) and lockwashers (33).
13. Place the cylinder (11) in position, and retain with the pins (18 and 16) at the yoke and the A-frame. Secure each pin with two kliprings (23). Remove the lifting tackle.
14. Install the left hand yoke (14), right hand yoke (13) and shims (15). Retain each yoke with two hexagon head bolts (30, 31 or 32), nuts (34) and lockwashers (33).
15. Place the push frame (3) into position at the A-frame attachment points. Install the two pins (20), and secure with the kliprings (24).
16. Install the lift link (6) between the push frame and yoke, and retain with the two pins (17 and 18). Secure each pin with two kliprings (23).
17. Attach suitable lifting tackle to the bulldozer blade (1, 8 or 10) and place into position at the push frame attachment points. Install the three pins (22), and secure with the kliprings (25).
18. Install the two upper push arms (2) at the right and left hand yokes. Install the two pins (19), and secure with the kliprings (24).
19. Connect the upper push arms with the bulldozer blade brackets. Install the two pins (22), and secure with the kliprings (25). Remove the lifting tackle.

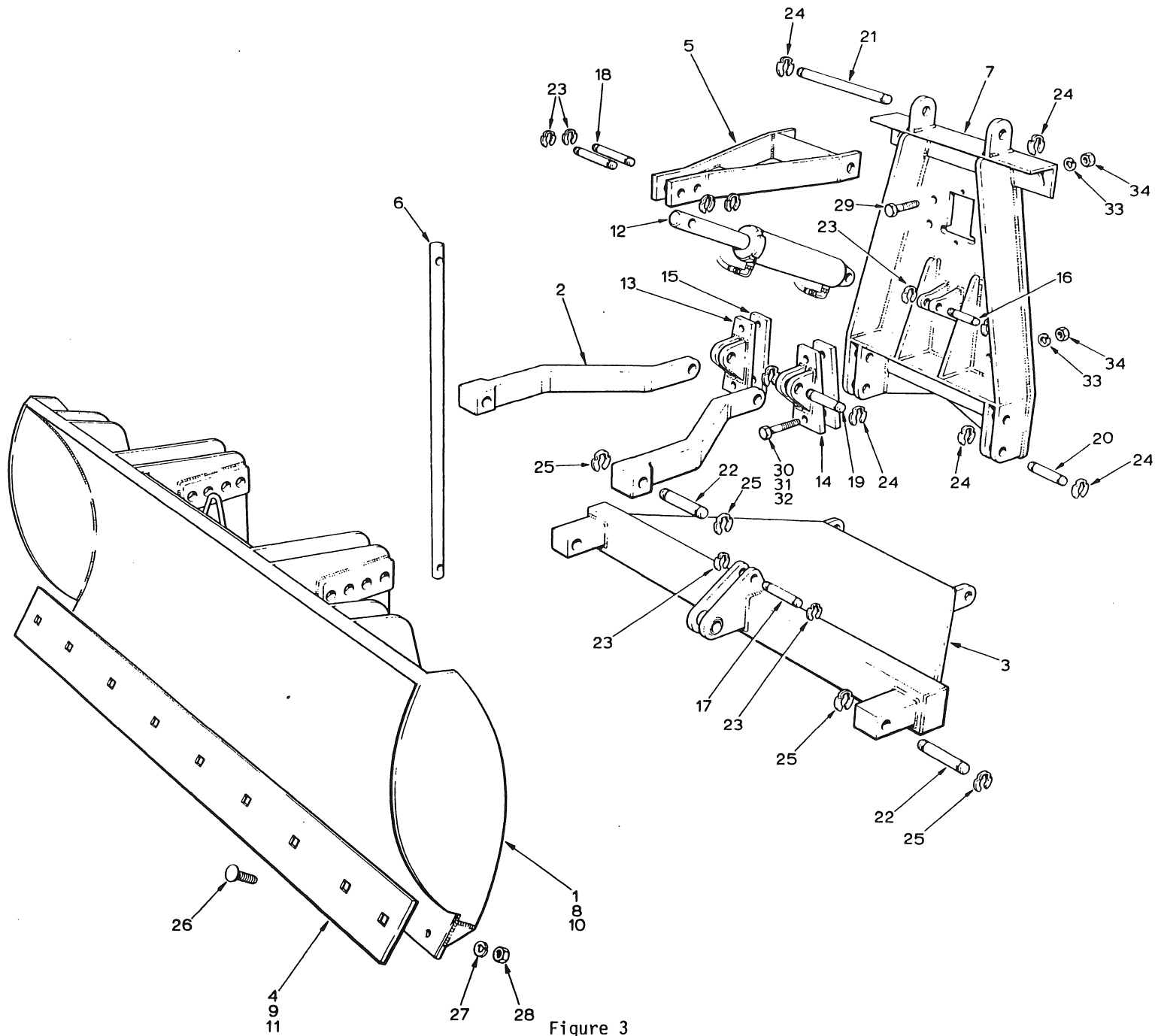

Figure 3



## ATTACHMENTS

REF. NO.	DESCRIPTION	REF. NO.	DESCRIPTION
1	8 FT. BULLDOZER BLADE	18	1" DIA. X 5 3/4" LG. PIN
2	UPPER PUSH ARM	19	1 1/4" DIA. X 4 1/4" LG. PIN
3	PUSH FRAME	20	1 1/4" DIA. X 5" LG. PIN
4	8 FT. EDGE	21	1 1/4" DIA. X 19" LG. PIN
5	YOKE	22	1 1/2" DIA. X 8 1/4" LG. PIN
6	LIFT LINK	23	KLIPRING FASTENER
7	A-FRAME	24	KLIPRING FASTENER
8	9 FT. BULLDOZER BLADE	25	KLIPRING FASTENER
9	9 FT. EDGE	26	2 1/2" LG. CARRIAGE BOLT
10	10 FT. BULLDOZER BLADE	27	LOCKWASHER
11	10 FT. EDGE	28	NUT
12	CYLINDER	29	4 1/2" LG. HEX. HD. BOLT
13	YOKE - R.H.	30	6 1/2" LG. HEX. HD. BOLT
14	YOKE - L.H.	31	7" LG. HEX. HD. BOLT
15	SHIM	32	8 1/2" LG. HEX. HD. BOLT
16	1" DIA. X 4 1/4" LG. PIN	33	LOCKWASHER
17	1" DIA. X 4 1/2" LG. PIN	34	NUT

### KEY TO FIG. 3

- |  |  |
|--|--|
| <p>20. Re-connect the hydraulic hoses to the frame and cylinder, ensuring that each hose is connected to its corresponding fitting.</p> <p>21. <u>Adjustments</u> (Figs. 3 and 4). The blade pitch can be varied by removing the upper push arm pins, tilting the blade to the desired angle; then installing the pins in the nearest alternative holes (1, Fig. 4).</p> | <p>22. Worn edges (4, 9 or 11, Fig. 3) can be replaced by removing the required quantity of carriage bolts (26, Fig. 3), nuts (28, Fig. 3), and lockwashers (27, Fig. 3); then removing the edge.</p> <p>23. Install a new edge, and retain with the carriage bolts, nuts and lockwashers.</p> |
|--|--|

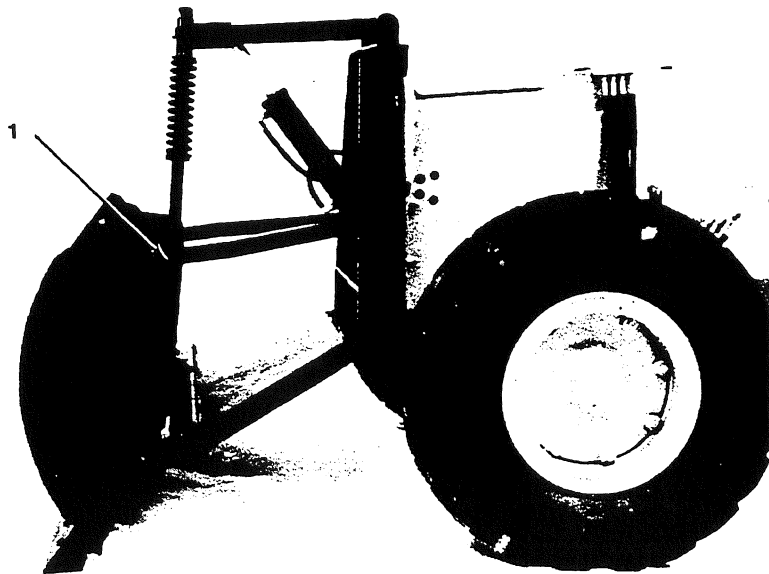

Figure 4

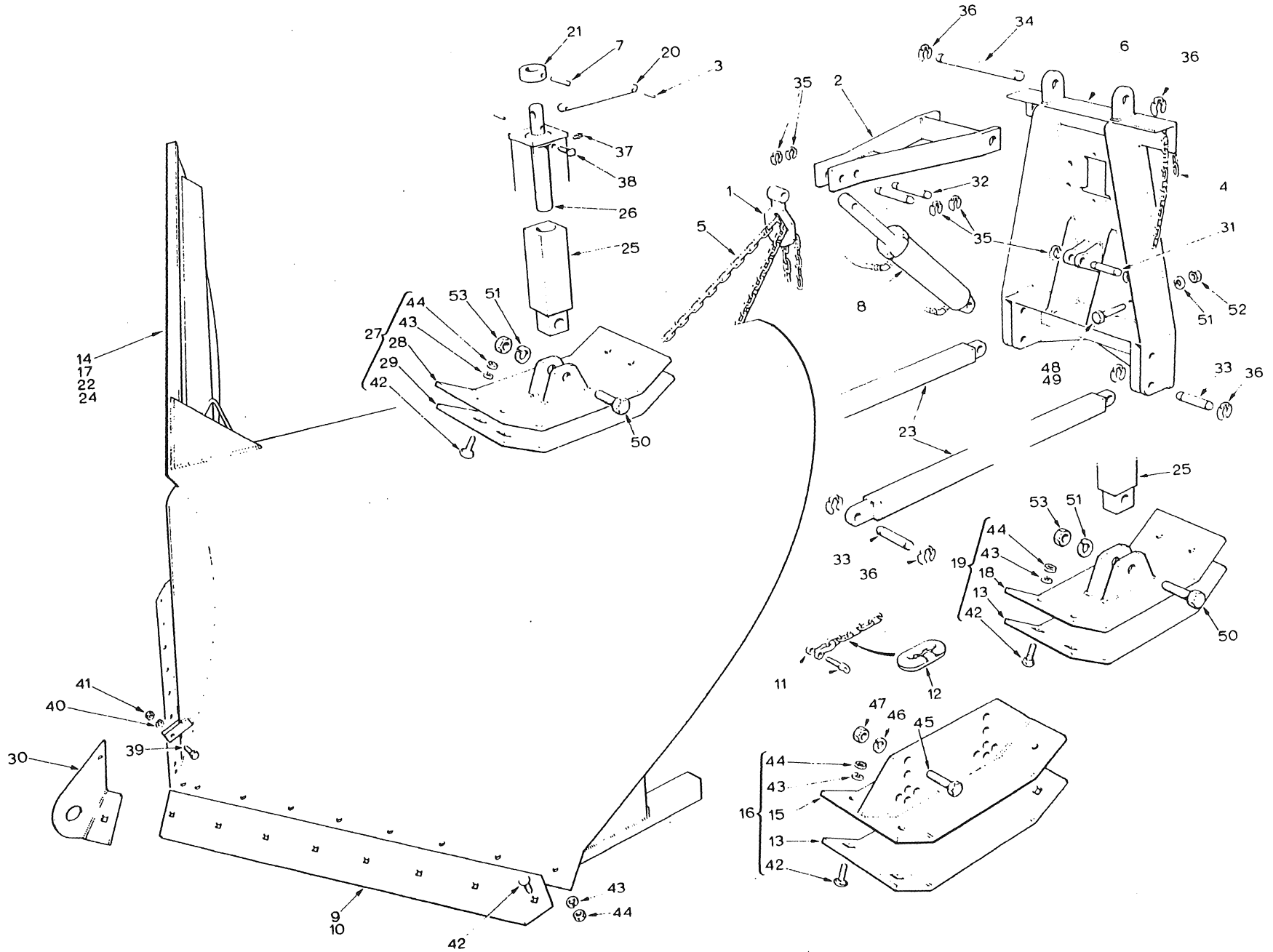

Figure 5

ATTACHMENTS

REF. NO.	DESCRIPTION	REF. NO.	DESCRIPTION
1	SPADE	28	INNER SHOE
2	YOKE	29	OUTER SHOE
3	1/4" X 1 1/4" LG. ROLL PIN	30	NOSE PIECE
4	CHAIN - 90" LG.	31	1" DIA. X 4 1/4" LG. PIN
5	CHAIN - 150" LG.	32	1" DIA. X 5 3/4" LG. PIN
6	A-FRAME	33	1 1/4" DIA. X 5" LG. PIN
7	3/8" X 2" LG. ROLL PIN	34	1 1/4" DIA. X 19" LG. PIN
8	CYLINDER	35	KLIPIRING FASTENER
9	EDGE - 9 FT. PLOW	36	KLIPIRING FASTENER
10	EDGE - 10 FT. PLOW	37	STRAIGHT GREASE FITTING
11	SHACKLE	38	1 1/2" LG. SQ. HD. SET SCREW
12	SPLICE LINK	39	2" LG. HEX. HD. BOLT
13	OUTER SHOE	40	LOCKWASHER
14	9 FT. V-PLOW - STANDARD SHOE TYPE	41	NUT
15	INNER SHOE	42	2 1/4" LG. CARRIAGE BOLT
16	SHOE ASSY. - STANDARD	43	LOCKWASHER
17	9 FT. V-PLOW - ADJUSTABLE SHOE TYPE	44	NUT
18	INNER SHOE	45	2 1/2" LG. HEX. HD. BOLT
19	SHOE ASSY. - REAR	46	LOCKWASHER
20	HANDLE - ADJUSTING SCREW	47	NUT
21	STOP RING	48	4 1/2" LG. HEX. HD. BOLT
22	10 FT. V-PLOW - STANDARD SHOE TYPE	49	6 1/2" LG. HEX. HD. BOLT
23	PUSH ROD	50	4" LG. HEX. HD. BOLT
24	10 FT. V-PLOW -ADJUSTABLE SHOE TYPE	51	LOCKWASHER
25	SWIVEL EXTENSION	52	NUT
26	ADJUSTING SCREW	53	NUT
27	SHOE ASSY. - FRONT		

KEY TO FIG. 5

V-PLOW (CHAIN LIFT)

1. Removal and Disassembly (Fig. 5).

WARNING:

Before disconnecting any hydraulic hoses or fittings, lower the V-plow onto the ground.

The V-plow hydraulic circuit is connected to the right hand side of the manifold valve either directly, or through a manually operated selector valve if a scarifier is installed.

2. If the V-plow cylinder is not to be removed, no action on the hydraulic circuit is required. However, if the V-plow cylinder is to be removed, it will be necessary to disconnect the hoses from the fittings on the grader nose side plates.
3. After identifying each hose with its corresponding fitting to ensure correct assembly, disconnect the hoses from the frame and cylinder. Plug the open ports.
4. Attach suitable lifting tackle to the V-plow blade (14, 17, 22 or 24). Remove the chains (4 and 5) from the spade (1) and the A-frame. Remove the klipring fasteners (36) securing the pins (33) connecting the push rods (23) to the V-

plow blade frame. Remove the pins. Hoist the V-plow blade away from the grader.

5. Remove the klipring fasteners (36) securing the pins (33) connecting the push rods to the A-frame (6). Remove the pins and the push rods.
6. Attach suitable lifting tackle to the yoke (2). Remove the klipring fasteners (35) securing the pin (32) connecting the spade to the yoke. Remove the pin and spade.
7. Remove the klipring fasteners (35) securing the two pins (31 and 32) connecting the cylinder (8) to the A-frame and yoke. Remove the pins and cylinders.
8. Arrange the hoist in such a way that the lifting tackle will support the weight of the A-frame. Remove the eight hexagon head capscrews (48 or 49), nuts (52) and lockwashers (51). Lower the A-frame onto the ground. Remove the two klipring fasteners (36) securing the pin (34). Remove the pin and the yoke. Hoist the A-frame away from the grader. Remove the lifting tackle.
9. Assembly and Installation (Fig. 5). Install the yoke (2) onto the A-frame (6), and retain with the pin (34). Secure the pin with two kliprings (36).

## ATTACHMENTS

10. Attach suitable lifting tackle to the yoke. Hoist the yoke and A-frame into position on the grader nose plate. Install the eight hexagon head bolts (48 or 49), nuts (52) and lockwashers (51).
11. Place the cylinder (8) in position, and retain with the pins (32 and 31) at the yoke and the A-frame. Secure each pin with two kliprings (35). Remove the lifting tackle.
12. Install the spade (1), and retain with the pin (32). Secure the pin with two kliprings (35).
13. Place the push rods (23) into position at the A-frame attachment points. Install the two pins (33), and secure with the kliprings (36).
14. Attach suitable lifting tackle to the V-plow blade (14, 17, 22 or 24) and place into position at the push rod attachment points. Install the two pins (33), and secure with the kliprings (36). Install the four chains (4 and 5), to the spade and the A-frame. Remove the lifting tackle.
15. Re-connect the hydraulic hoses to the frame and cylinder, ensuring that each hose is connected to its corresponding fitting.
16. Adjustments (Figs. 5, 6 and 7). The plow shoes should be adjusted so that the edges of the plow are high enough to prevent scraping the road surface (1, Fig. 6). Two types of shoe adjustment are available as follows:
  - a. Standard Shoes. Four standard shoes (16, Fig. 5) - two front, two rear are retained on the V-plow blade frame by two hexagon head bolts (45, Fig. 5), nuts (47, Fig. 5) and lockwashers (46, Fig. 5) per shoe. Adjustment is effected by raising the V-plow blade off the ground, removing the hardware, selecting the new position and installing the hardware into the alternative holes. Lower the blade.
  - b. Optional Shoes. Three shoes - one front (27, Fig. 5), two rear (19, Fig. 5) - are available as an optional arrangement, and are connected to an adjustment screw and swivel assembly by one hexagon head bolt (50, Fig. 5), nut (53, Fig. 5) and lockwasher (51, Fig. 5) per shoe. Adjustment is effected by raising the V-plow blade off the ground and turning the adjusting screw handle (20, Fig. 5) until the desired height is obtained. Lower the blade.
17. If the V-plow blade tends to tip to one side or the other when being raised or lowered, remove any slack in the chains (4, Fig. 5) by adjusting at the A-frame slots. Similarly, remove any slack in the chains (5, Fig. 5) by adjusting at the spade slots until a level movement is obtained (1, Fig. 7).
18. Worn edges (9 or 10, Fig. 5) can be replaced by removing the required quantity of carriage bolts (42, Fig. 5), nuts (44, Fig. 5) and lockwashers (43, Fig. 5); then removing the edges.

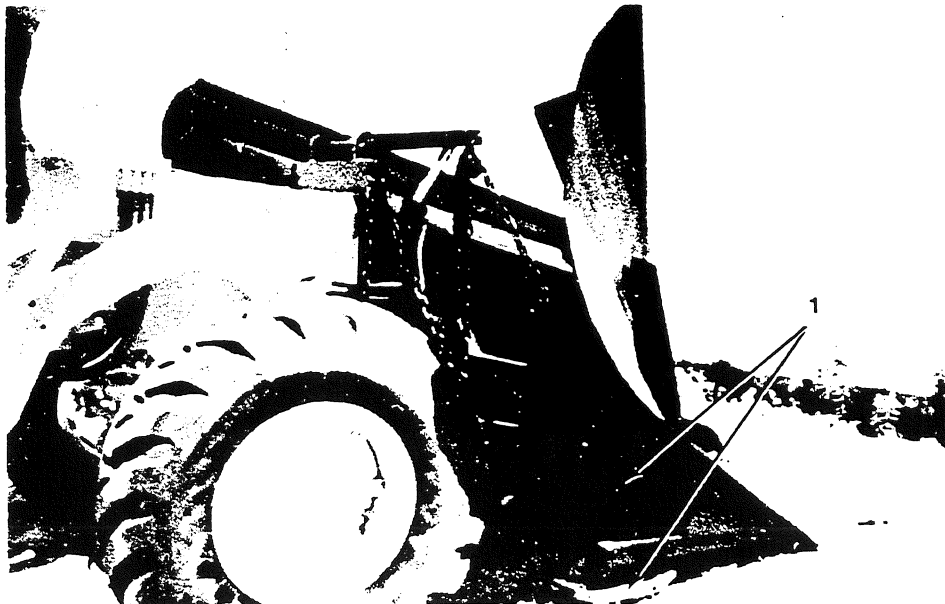

Figure 6

## ATTACHMENTS

19. Install a new edge, and retain with the carriage bolts, nuts and lockwashers.
20. Worn outer shoes (13 and 29, Fig. 5) can be replaced by removing the required quantity of carriage bolts (42, Fig. 5), nuts (44, Fig. 5) and lockwashers (43, Fig. 5); then removing the outer shoe.
21. Install a new outer shoe, and retain with the carriage bolts, nuts and lockwashers.

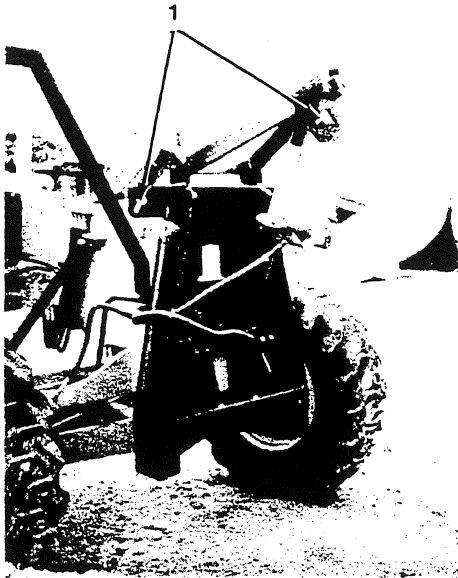

Figure 7

### V-PLOW (DOWN PRESSURE)

1. Removal and Disassembly (Fig. 8).

#### WARNING:

Before disconnecting any hydraulic hoses or fittings, lower the V-plow blade onto the ground.

The V-plow hydraulic circuit is connected to the right hand side of the manifold valve either directly, or through a manually operated selector valve if a scarifier is installed.

2. If the V-plow cylinder is not to be removed, no action on the hydraulic circuit is required. However, if the V-plow cylinder is to be removed, it will be necessary to disconnect the hoses from the fittings on the grader nose side plates.
3. After identifying each hose with its corresponding fitting to ensure correct assembly, disconnect the hoses from the frame and cylinder. Plug the open ports.

4. Attach suitable lifting tackle to the V-plow blade (19, 22, 27 or 28). Remove the klipring fasteners (43 and 42) securing the pins (40 and 37) connecting the upper push arms (1) to the V-plow blade frame and the yokes (12 and 13). Remove the pins and upper push arms.
5. Remove the klipring fasteners (43) securing the three pins (40) connecting the push frame (2) to the V-plow blade frame. Remove the pins. Hoist the V-plow blade away from the grader.
6. Remove the two kliprings (41) securing the pin (36). Remove the lift link (4) from the push frame. Remove the nut and jam nut (65) and two flatwashers (64). Remove the lift link, together with the spring (16) and collar (6).
7. Remove the klipring fasteners (42) securing the two pins (38) connecting the push frame to the A-frame (9). Remove the pins and the push frame.
8. Attach suitable lifting tackle to the yoke (3). Remove the two hexagon head bolts (59), nuts (62) and lockwashers (61). Lower the cylinder (11). Remove the two yoke extensions (7), together with the sleeve (5).
9. Remove the two kliprings (41) securing the pin (35). Remove the pin and cylinder.
10. Arrange the hoist in such a way that the lifting tackle will support the weight of the A-frame. Remove the four hexagon head bolts (56, 57 or 58), nuts (62) and lockwashers (61) retaining the left hand yoke (13) and right hand yoke (12). Remove the yokes and shims (17).
11. WARNING:  
Ensure that the A-frame is securely attached to the lifting tackle.  
  
Remove the four hexagon head bolts (55), nuts (62) and lockwashers (61). Lower the A-frame onto the ground. Remove the two klipring fasteners (42) securing the pin (39). Remove the pin and the yoke. Hoist the A-frame away from the grader. Remove the lifting tackle.
12. Assembly and Installation (Fig. 8). Install the yoke (3) onto the A-frame (9), and retain with the pin (39). Secure the pin with two kliprings (42).
13. Attach suitable lifting tackle to the yoke. Hoist the yoke and A-frame into

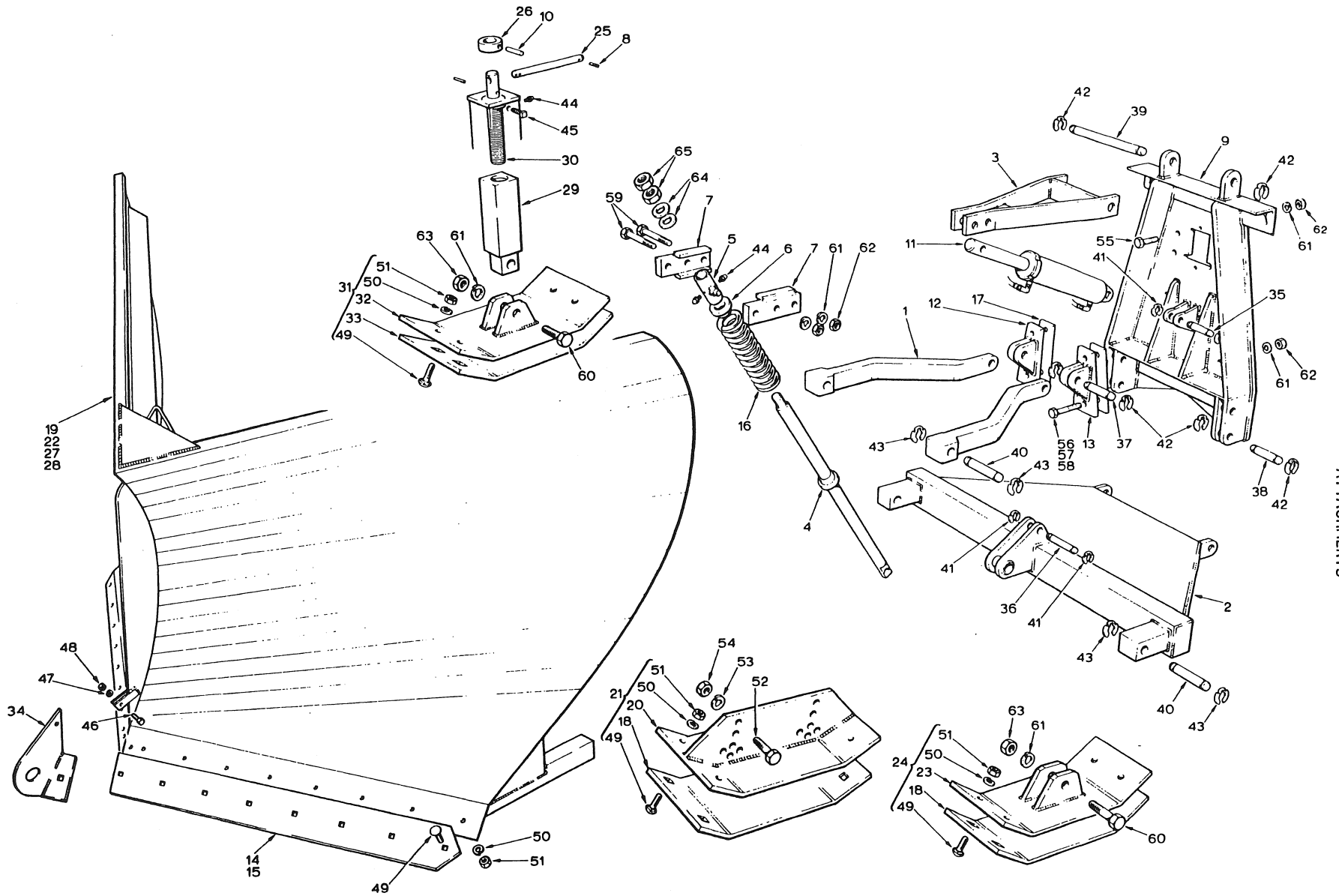

ATTACHMENTS

Figure 8

ATTACHMENTS

REF. NO.	DESCRIPTION	REF. NO.	DESCRIPTION
1	UPPER PUSH ARM	34	NOSE PIECE
2	PUSH FRAME	35	1" DIA. X 4 1/4" LG. PIN
3	YOKE	36	1" DIA. X 4 1/2" LG. PIN
4	LIFT LINK	37	1 1/4" DIA. X 4 1/4" LG. PIN
5	SLEEVE	38	1 1/4" DIA. X 5" LG. PIN
6	COLLAR	39	1 1/4" DIA. X 19" LG. PIN
7	YOKE EXTENSION	40	1 1/2" DIA. X 8 1/4" LG. PIN
8	1/4" X 1 1/4" LG. ROLL PIN	41	KLIPRING FASTENER
9	A-FRAME	42	KLIPRING FASTENER
10	3/8" X 2" LG. ROLL PIN	43	KLIPRING FASTENER
11	CYLINDER	44	STRAIGHT GREASE FITTING
12	YOKE - R.H.	45	1 1/2" SQ. HD. SET SCREW
13	YOKE - L.H.	46	2" LG. HEX. HD. BOLT
14	EDGE - 9 FT. PLOW	47	LOCKWASHER
15	EDGE - 10 FT. PLOW	48	NUT
16	SPRING	49	2 1/4" CARRIAGE BOLT
17	SHIM	50	LOCKWASHER
18	OUTER SHOE	51	NUT
19	9 FT. V-PLOW - STANDARD SHOE TYPE	52	2 1/2" LG. HEX. HD. BOLT
20	INNER SHOE	53	LOCKWASHER
21	SHOE ASSY. - STANDARD	54	NUT
22	9 FT. V-PLOW - ADJUSTABLE SHOE TYPE	55	4 1/2" LG. HEX. HD. BOLT
23	INNER SHOE	56	6 1/2" LG. HEX. HD. BOLT
24	SHOE ASSY. - REAR	57	7" LG. HEX. HD. BOLT
25	HANDLE - ADJUSTING SCREW	58	8 1/2" LG. HEX. HD. BOLT
26	STOP RING	59	8" LG. HEX. HD. BOLT
27	10 FT. V-PLOW - STANDARD SHOE TYPE	60	4" LG. HEX. HD. BOLT
28	10 FT. V-PLOW - ADJUSTABLE SHOE TYPE	61	LOCKWASHER
29	SWIVEL EXTENSION	62	NUT
30	ADJUSTING SCREW	63	NUT
31	SHOE ASSY. - FRONT	64	FLATWASHER
32	INNER SHOE	65	NUT
33	OUTER SHOE		

KEY TO FIG. 8

position on the grader nose plate. Install the four hexagon head bolts (55), nuts (62) and lockwashers (61).

14. Place the cylinder at its position on the A-frame, and retain with the pin (35). Secure the pin with two kliprings (41).
15. Lower the yoke. Install the two yoke extensions (7), together with the sleeve (5) - engaging the trunnion pins in the front holes. Align the cylinder piston rod with the rear holes of the yoke. Install the two hexagon head bolts (59), nuts (62) and lockwashers (61).
16. Install the left hand yoke (13), right hand yoke (12) and shims (17). Retain each yoke with two hexagon head bolts (56, 57 or 58), nuts (62) and lockwashers (61).
17. Place the push frame (2) into position at the A-frame attachment points. Install the two pins (38) and secure with the kliprings (42).
18. Install the spring (16) and collar (6)

onto the lift link (4). Insert the lift link through the sleeve, and secure with the nut and jam nut (65) and two flatwashers (64). Install the lower end of the lift link at the push frame, and retain with the pin (36). Secure the pin with two kliprings (41).

19. Attach suitable lifting tackle to the V-plow blade (19, 22, 27 or 28), and place into position at the push frame attachment points. Install the three pins (40), and secure with the kliprings (43).
20. Install the two upper push arms (1) at the right and left hand yokes. Install the two pins (37), and secure with the kliprings (42).
21. Connect the upper push arms with the V-plow blade frame. Install the two pins (40), and secure with the kliprings (43). Remove the lifting tackle.
22. Re-connect the hydraulic hoses to the frame and cylinder, ensuring that each hose is connected to its corresponding fitting.

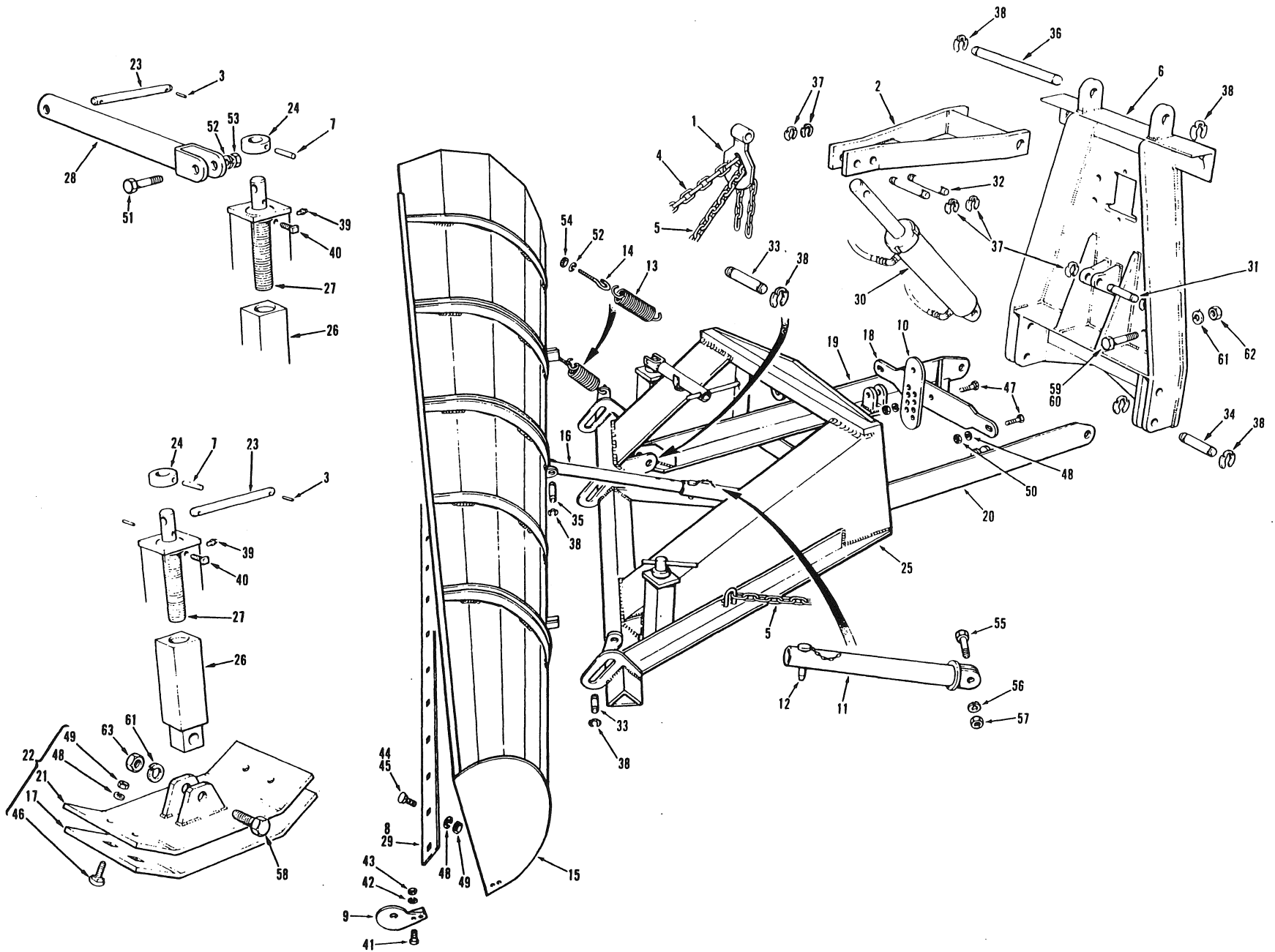

ATTACHMENTS

Figure 9



ATTACHMENTS

REF. NO.	DESCRIPTION	REF. NO.	DESCRIPTION
1	SPADE	33	1 1/4" DIA. X 4 1/2" LG. PIN
2	YOKE	34	1 1/4" DIA. X 5" LG. PIN
3	1/4" DIA. X 1 1/4" LG. ROLL PIN	35	1 1/4" DIA. X 5 1/4" LG. PIN
4	CHAIN - 72" LG.	36	1 1/4" DIA. X 19" LG. PIN
5	CHAIN - 84" LG.	37	KLIPRING FASTENER
6	A-FRAME	38	KLIPRING FASTENER
7	3/8" DIA. X 2" LG. ROLL PIN	39	STRAIGHT GREASE FITTING
8	EDGE	40	1 1/2" LG. SQ. HD. SET SCREW
9	NOSE PIECE	41	1 3/4" LG. HEX. HD. BOLT
10	STABILIZER BAR	42	LOCKWASHER
11	ADJUSTING LINK - OUTER	43	NUT
12	SHEAR PIN	44	2" LG. CARRIAGE BOLT
13	SPRING	45	2" LG. PLOW BOLT
14	EYE BOLT	46	2 1/4" LG. CARRIAGE BOLT
15	MOLDBOARD	47	2 1/2" LG. HEX. HD. BOLT
16	ADJUSTING LINK - INNER	48	LOCKWASHER
17	OUTER SHOE	49	NUT
18	CROSS BAR	50	NUT
19	SHORT PUSH ROD - R.H.	51	2 3/4" LG. HEX. HD. BOLT
20	LONG PUSH ROD - L.H.	52	LOCKWASHER
21	INNER SHOE	53	NUT
22	SHOE ASSY. - ADJUSTABLE	54	NUT
23	HANDLE - ADJUSTING SCREW	55	3" LG. HEX. HD. BOLT
24	STOP RING	56	LOCKWASHER
25	PUSH FRAME	57	NUT
26	SWIVEL EXTENSION	58	4" LG. HEX. HD. BOLT
27	ADJUSTING SCREW	59	4 1/2" LG. HEX. HD. BOLT
28	SCREW EXTENSION	60	6 1/2" LG. HEX. HD. BOLT
29	EDGE	61	LOCKWASHER
30	CYLINDER	62	NUT
31	1" DIA. X 4 1/4" LG. PIN	63	NUT
32	1" DIA. X 5 3/4" LG. PIN		

KEY TO FIG. 9

23. Adjustments (Fig. 8). The plow shoes should be adjusted so that the edges of the plow are high enough to prevent scraping the road surface. Two types of shoe adjustments are available as follows:
- a. Standard Shoes. Four standard shoes (21) - two front, two rear - are re-retained on the V-plow blade frame by two hexagon head bolts (52), nuts (54) and lockwashers (53) per shoe. Adjustment is effected by raising the V-plow blade off the ground, removing the hardware, selecting the new position and installing the hardware into the alternative holes. Lower the blade.
  - b. Optional Shoes. Three shoes - one front (31), two rear (24) - are available as an optional arrangement, and are connected to an adjustment screw and swivel assembly by one hexagon head bolt (60), nut (63) and lockwasher (61) per shoe. Adjustment is effected by raising the V-plow blade off the ground and turning the adjusting screw handle (25) until the desired height is obtained. Lower the blade.
24. Worn edges (14 or 15) can be replaced by removing the required quantity of carriage bolts (49), nuts (51) and lockwashers (50); then removing the edges.
25. Install a new edge, and retain with the carriage bolts, nuts and lockwashers.
26. Worn outer shoes (18 and 33) can be replaced by removing the required quantity of carriage bolts (49), nuts (51) and lockwashers (50); the removing the outer shoe.
27. Install a new outer shoe, and retain with the carriage bolts, nuts and lockwashers.
- ONE-WAY PLOW
1. Removal and Disassembly (Fig. 9).
 

WARNING:  
Before disconnecting any hydraulic hoses or fittings, lower the one-way plow onto the ground.

The one-way plow hydraulic circuit is connected to the right hand side of the manifold valve either directly, or through a manually operated selector valve if a scarifier is installed.

## ATTACHMENTS

2. If the one-way plow cylinder is not to be removed, no action on the hydraulic circuit is required. However, if the one-way plow cylinder is to be removed, it will be necessary to disconnect the hoses from the fittings on the grader nose side plates.
3. After identifying each hose with its corresponding fitting to ensure correct assembly, disconnect the hoses from the frame and cylinder. Plug the open ports.
4. Attach suitable lifting tackle to the one-way snow plow blade (15). Remove the two kliprings (38) securing the pin (35) connecting the inner adjusting link (16) to the snow plow blade frame bracket. Remove the nuts (54) and lockwashers (52) securing the eyebolts (14) and springs (13).
5. Remove the kliprings (38) securing the pins (33) connecting the push frame (25) to the snow plow blade frame. Remove the pins. Hoist the one-way snow plow blade away from the grader.
6. Remove the kliprings (38) securing the pins (34) connecting the long and short push bars (20 and 19) to the A-frame (6). Remove the pins. Remove the two chains (4, 5) from the spade (1). Hoist the push frame away from the grader.
7. Remove the hexagon head bolt (55), nut (57) and lockwasher (56) securing the outer adjusting link (11) to the push frame. The inner and outer adjusting links can be separated by removing the shear pin (12).
8. Remove the hexagon head bolt (47), nut (50) and lockwasher (48) securing the stabilizer bar (18) to the vertical adjustment bar (10). Remove the hexagon head bolt, nut and lockwasher securing the vertical adjustment bar to the push frame.
9. Remove the two hexagon head bolts (47), nuts (50) and lockwashers (48) securing the stabilizer bar to the long and short push bars. Remove the kliprings (38) securing the pins (33) connecting the push bars to the push frame. Remove the pins and push bars.
10. Attach suitable lifting tackle to the yoke (2). Remove the klipring fasteners (37) securing the pin (32) connecting the spade to the yoke. Remove the pin and spade.
11. Remove the klipring fasteners (32) securing the two pins (31 and 32) connecting the cylinder (30) to the A-frame and yoke. Remove the pins and cylinder.
12. **WARNING:**  
Ensure that the A-frame is securely attached to the lifting tackle.  
Arrange the hoist in such a way that the lifting tackle will support the weight of the A-frame. Remove the eight hexagon head bolts (59 or 60), nuts (62) and lockwashers (61). Lower the A-frame onto the ground. Remove the two klipring fasteners (38) securing the pin (36). Remove the pin and the yoke. Hoist the A-frame away from the grader. Remove the lifting tackle.
13. Assembly and Installation (Fig. 9). Install the yoke (2) onto the A-frame (6), and retain with the pin (36). Secure the pin with two kliprings (38).
14. Attach suitable lifting tackle to the yoke. Hoist the yoke and A-frame into position on the grader nose plate. Install the eight hexagon head bolts (59 or 60), nuts (62) and lockwashers (61).
15. Place the cylinder (30) in position, and retain with the pins (31 and 32) at the yoke and the A-frame. Secure each pin with two kliprings (37). Remove the lifting tackle.
16. Install the spade (1), and retain with the pin (32). Secure the pin with two kliprings (37).
17. Place the long and short push bars (20 and 19) (left hand side and right hand side, respectively) into position at the push frame. Install the two pins (33), and secure with the kliprings (38).
18. Install the stabilizer bar (18), and secure to the push bars with the two hexagon head capscrews (47), nuts (50) and lockwashers (48).
19. Install the vertical adjustment bar (10), and secure with the hexagon head bolt (47), nut (50) and lockwasher (48). Secure the stabilizer bar to the vertical adjustment bar with the hexagon head bolt, nut and lockwasher.
20. Insert the inner adjusting link (16) into the outer adjusting link (11), and secure with the shear pin (12). Secure the outer adjusting link to the push frame with the hexagon head bolt (55), nut (57) and lockwasher (56).
21. Attach suitable lifting tackle to the push frame (25) and place in position at the A-frame attachment points. Install the two pins (34), and secure with the kliprings (38). Remove the lifting tackle.

## ATTACHMENTS

22. Attach the hoist to the one-way snow plow blade (15) and place into position at the push frame attachment points. Install the three pins (33), and secure with the kliprings (38).
23. Install the eyebolts (14) and springs (13), and secure with the nuts (54) and lockwashers (52). Install the two chains (4, 5) into the slots of the spade. Secure the inner adjusting link with the pin (35), and install the two kliprings (38). Remove the lifting tackle.
24. Re-connect the hydraulic hoses to the frame and cylinder, ensuring that each hose is connected to its corresponding fitting.
25. Adjustments (Figs. 9 and 10). The plow shoes should be adjusted so that the edge of the plow is high enough to prevent scraping the road surface.
26. Two shoes (22, Fig. 9) are connected to an adjustment screw and swivel assembly by one hexagon head bolt (58, Fig. 9), nut (63, Fig. 9) and lockwasher (61, Fig. 9) per shoe. Adjustment is effected by raising the one-way plow blade off the ground and turning the adjusting screw handle (23, Fig. 9) until the desired height is obtained (4, Fig. 10). Lower the blade.
27. The blade pitch can be varied by removing the shear pin connecting the inner and outer adjusting link, tilting the blade to the desired angle; then installing the shear pin in the alternative hole (3, Fig. 10).
28. If the one-way plow tends to tip to one side or the other when being raised or lowered, remove any slack in the chains by adjusting at the spade slots until a level movement is obtained (1, Fig. 10).

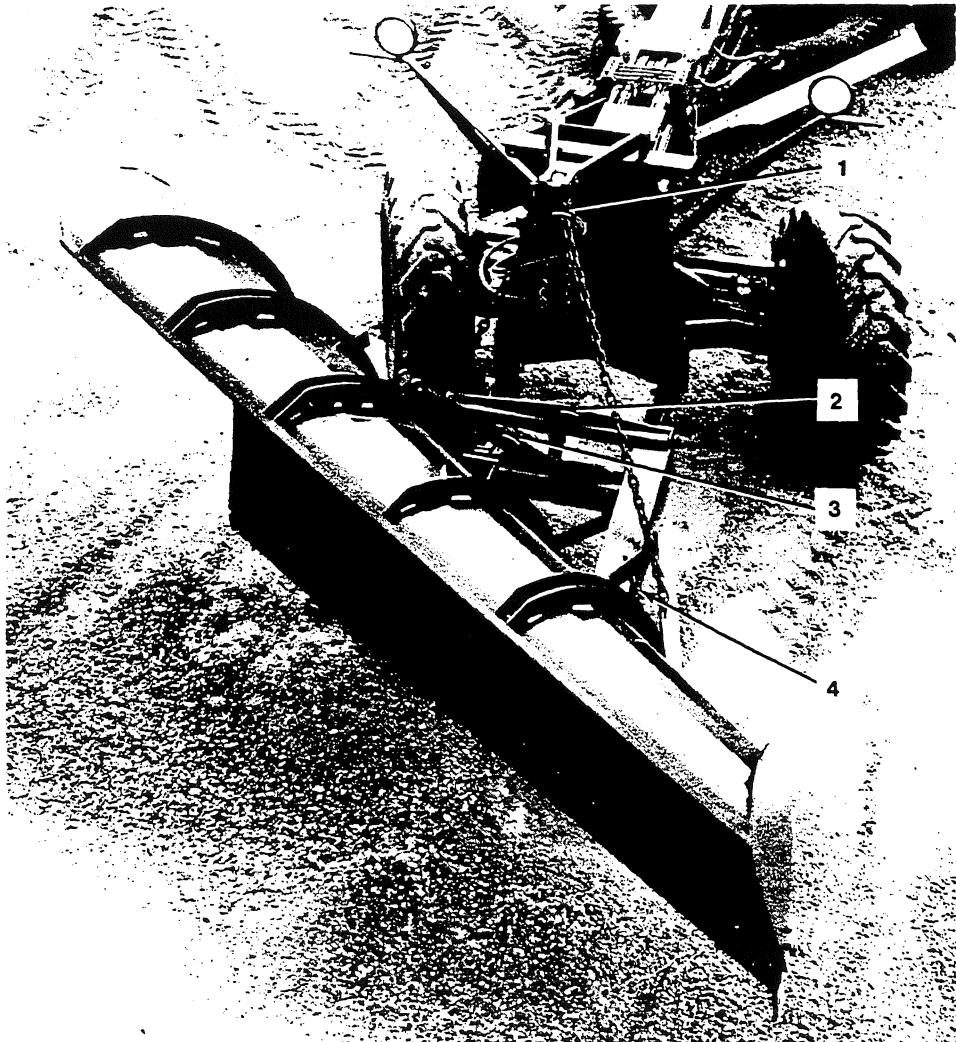

Figure 10

## ATTACHMENTS

29. To accommodate for differences in tire sizes, position the stabilizer bar to suit these conditions, and install the hardware in the appropriate hole of the vertical adjustment bar (2, Fig. 10).
  30. A worn edge (8 or 29, Fig. 9) can be replaced by removing the quantity of carriage bolts (44 and 45, Fig. 9), nuts (49, Fig. 9) and lockwashers (48, Fig. 9); then removing the edge.
  31. Install a new edge, and retain with the carriage bolts, nuts and lockwashers.
  32. Worn outer shoes (17, Fig. 9) can be replaced by removing the required quantity of carriage bolts (46, Fig. 9), nuts (49, Fig. 9) and lockwashers (48, Fig. 9); then removing the outer shoe.
  33. Install a new outer shoe, and retain with the carriage bolts, nuts and lockwashers.
5. Attach suitable lifting tackle to both sides of the lower pull arm (7). Remove the hexagon head capscrews (22) and lockwashers (23) retaining the pins (10 and 13). Remove the pins, and hoist the lower pull arm away from the grader. Inspect the bearing bushes (15 and 16) for serviceability. Replace faulty bushings.
  6. Remove the two roll pins (17) and the flatwashers (24) retaining the upper control rods (8) on the ripper mounting bracket pins. Remove the upper control rods. Inspect the bearing bushings (16) for serviceability. Replace faulty bushings.
  7. Remove the hexagon head capscrews (22) and lockwashers (23) retaining the pins (12). Remove the pins and cylinders (9).
  8. Attach suitable lifting tackle to the mounting brackets (4 and 5). Remove the hexagon head bolts (19), nuts (21) and lockwashers (20) (four per bracket). Hoist the mounting brackets away from the grader.

## RIPPER

1. Removal and Disassembly (Fig. 11).

### WARNING:

Before disconnecting any hydraulic hoses or fittings, lower the ripper onto the ground.

The ripper is controlled by a single solenoid valve mounted on the rear of the grader. Identify and disconnect the hoses from the cylinders, and the hose from the solenoid valve to the pressure relief valve located beneath the hydraulic tank.

2. Identify and disconnect the pressure hose, from the solenoid valve to the manifold valve supply hose, at the union fitting. Connect the manifold valve supply hose to the tee fitting at the pressure relief valve. Remove the electrical connections to the solenoid valve, and temporarily attach the wire harness to the grader frame.
3. Attach suitable lifting tackle to both sides of the ripper box (1). Remove and discard the cotter pins (18), and remove the flatwashers (24). Remove the ripper tooth pins (14) (two per tooth). Remove the ripper teeth (1).
4. Remove the hexagon head capscrews (22) and lockwashers (23) retaining the pins (10 and 11). Remove the pins, and hoist the ripper box away from the grader.

9. Assembly and Installation (Fig. 11).

### CAUTION:

When lubricating the bearing bushings in the ripper assembly, apply only a light smear of premium quality lithium-based grease; containing up to 3% molybdenum disulphide, or a silicone-based grease.

10. Attach suitable lifting tackle to the mounting brackets (4 and 5). Place the brackets into their positions on the grader frame, and retain with the hexagon head bolts (19), nuts (21) and lockwashers (20) (four per bracket).

### NOTE:

Do not tighten the hardware yet.

11. Install the two cylinders (9), and retain to the mounting brackets with the pins (12), hexagon head capscrews (22) and lockwashers (23).
12. Attach suitable lifting tackle to the lower pull arm (7). Lubricate the lower pull arm bearing bushings (15 and 16). Place the lower pull arm into its position with the mounting brackets, and retain with the two pins (13), hexagon head capscrews (22) and lockwashers (23). Raise the lower pull arm, and engage the piston rod yokes. Install the two pins (10), hexagon head capscrews (22) and lockwashers (23).

ATTACHMENTS

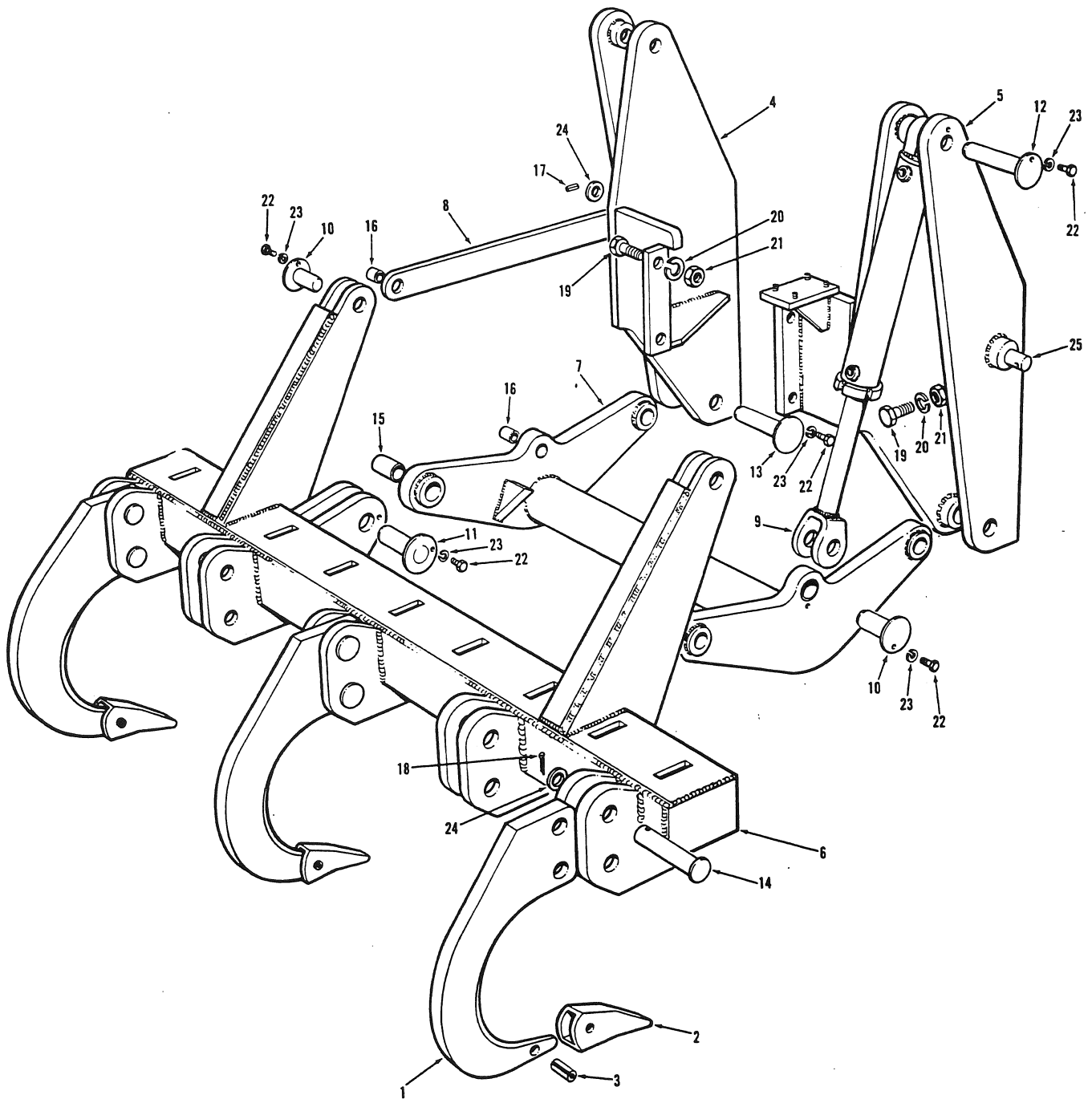

Figure 11

REF. NO.	DESCRIPTION
1	SHANK
2	POINT
3	PIN
4	MOUNTING BRACKET - L.H.
5	MOUNTING BRACKET - R.H.
6	RIPPER BOX
7	LOWER PULL ARM ASSY.
8	CONTROL ROD ASSY.
9	CYLINDER
10	1 1/2" DIA. PIN
11	2" DIA. PIN
12	1 1/2" DIA. PIN
13	2" DIA. PIN

REF. NO.	DESCRIPTION
14	TOOTH PIN
15	BUSHING
16	BUSHING
17	ROLL PIN
18	COTTER PIN
19	4" LG. HEX. HD. BOLT
20	LOCKWASHER
21	NUT
22	3/4" LG. HEX. HD. BOLT
23	LOCKWASHER
24	FLATWASHER
25	PIVOT STUD

KEY TO FIG. 11

## ATTACHMENTS

13. Attach suitable lifting tackle to the ripper box (6). Place the ripper box into its position with the lower pull arms, and retain with the two pins (11), hexagon head capscrews (22) and lockwashers (23).
  14. Lubricate the bearing bushings (16) in the two upper control rods. Raise the ripper box, and install the upper control rods. Retain the rods with the pins (10), hexagon head capscrews (22) and lockwashers (23). Install the flatwashers (24) and roll pins (17).
  15. Install the ripper tooth shanks (1), and retain with the pins (14), flatwashers (24) and new cotter pins (18) (two per tooth).
  16. Fully tighten the mounting bracket hardware.
  17. Disconnect the manifold valve supply hose at the pressure relief valve tee fitting. Re-connect the manifold valve supply hose to the pressure hose from the solenoid valve, at the union fitting.
  18. Re-connect the hose from the solenoid valve to the pressure relief valve, and the hoses to the cylinder. Install the electrical connections to the solenoid valve.
  19. Raise the lower the ripper, and ensure that no binding occurs in the linkage.
  20. Adjustments (Figs. 11 and 12). The pitch of the ripper can be adjusted manually by removing the two roll pins and flatwashers, moving the upper control rods to engage an alternative hole with the pins, and installing the flatwashers and roll pins (1. Fig. 12).
  21. Worn tooth points (2, Fig. 11) can be replaced by driving out the pin (3, Fig. 11) and removing the point (2, Fig. 12).
- NOTE:**  
The optional shank shield can be removed and replaced, if necessary.
22. Install a new point, and retain with the pin.

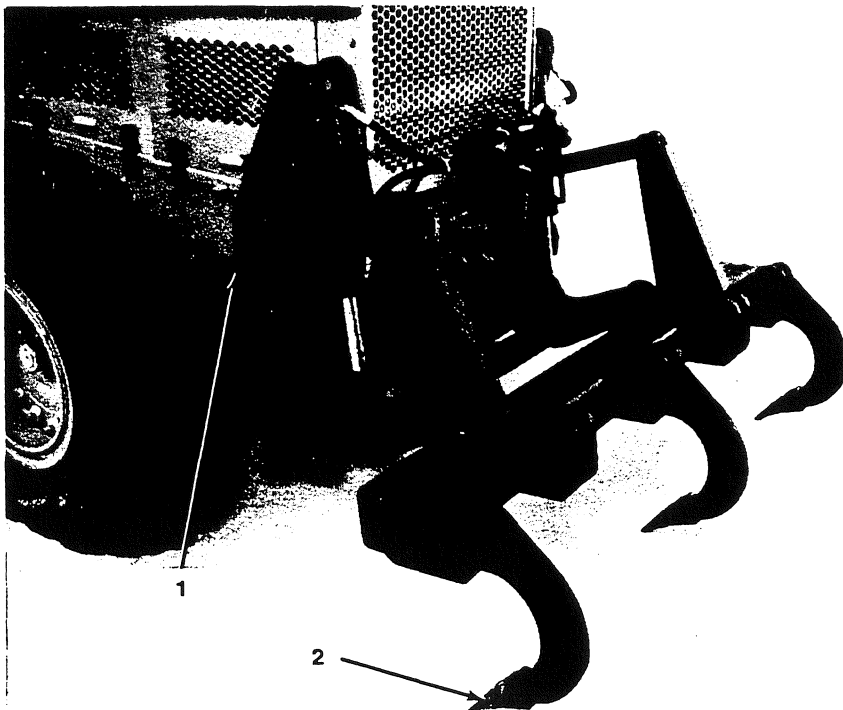

Figure 12

ATTACHMENTS

WINDROW ELIMINATOR

1. Removal and Disassembly (Fig. 13).

**WARNING:**

Before disconnecting any hydraulic hoses or fittings, lower the windrow eliminator onto the ground.

The windrow eliminator is controlled by a single solenoid valve mounted on the rear of the grader. Identify and disconnect the hoses from the cylinder, and the hose from the solenoid valve to the pressure relief valve located beneath the hydraulic tank.

2. Identify and disconnect the pressure hose, from the solenoid valve to the manifold valve supply hose, at the union fitting. Connect the manifold valve supply hose to the tee fitting at the pressure relief valve. Remove the electrical connections to the solenoid valve, and temporarily attach the wire harness to the grader frame.
3. Attach suitable lifting tackle to the two pull tubes (46). Remove and discard the two cotter pins (54). Remove the two flatwashers (78) and headed pins (3). Remove the two chains (81) from the chain plates (41). Remove the windrow eliminator from the grader.
4. To remove the A-frame (39) and components, proceed as follows:
  - a. Remove the hexagon head bolt (74), nut (75) and lockwasher (76) retaining each swivel (19). Remove the swivels.
  - b. Remove and discard the cotter pin (54), and remove the flatwasher (78) and headed pin (2) retaining each chain plate. Remove the chain plates.
  - c. Remove the two hexagon head bolts (73), nuts (75) and pal nuts (77) retaining the cylinder (21). Remove the cylinder, and discard the pal nuts.
  - d. Remove and discard the two cotter pins (54), and remove the flatwashers (78) and headed pins (1) retaining the lifting arm (40). Remove the lifting arm.
  - e. Attach suitable lifting tackle to the A-frame. Remove the eight hexagon head bolts (67), nuts (64) and lockwashers (65) retaining the A-frame to the grader frame. Carefully remove the A-frame, together with the two adapter plates. Hoist the A-frame away from the grader.

5. Remove the two lynch pins (26), and remove the adjustable drag link assembly.
6. Release the two shackles (4) securing the chains. Remove the shackles and chains. The chains, springs (20) and hook bars (28) are available as replacement parts.
7. Release the jam nut (72) and square head set screw (71) securing each pull collar (12). Carefully remove the two pull tubes from the tube and strap brackets (49), at the same time, retrieving the pull collars.
8. Release the jam nut (72) and square head set screw (71) securing each lift collar (45). Remove the lift collars.
9. To disassemble the tube and strap bracket assembly, proceed as follows:
  - a. Remove and discard the cotter pin (54), and remove the flatwasher (78) and headed pin (11). Remove the tube and strap bracket from the main rib plate (50).
  - b. Remove the hexagon head bolt (57), nut (58) and lockwasher (59) retaining the pivot pin (13). Remove the pivot pin and the main rib plate.
  - c. Remove the hexagon head bolts (66), nuts (64) and lockwashers (65) retaining the upper bracket (15) and lower bracket (14). Remove the brackets.
10. To disassemble the wheel adjustment spindle assembly, proceed as follows:
  - a. Remove the roll pins (44) retaining the two positioning washers (43).
  - b. Rotate the adjusting spindle (84) counter-clockwise, and remove from the nut housing (85). The handle (55) and collar (23) can be disassembled by removing the hexagon head bolts (55 and 57), nuts (58) and lockwashers (59). Retrieve the positioning washers.
  - c. Remove the two hexagon head bolts (63), nuts (64) and lockwashers (65) retaining the nut housing to the moldboard assembly (7), and remove the nut housing. Inspect the two scraper seals (86) for serviceability. Replace defective seals.
  - d. Remove the two hexagon head bolts (63), nuts (64) and lockwashers (65) retaining the lower spindle guide (24), and remove the guide.

## ATTACHMENTS

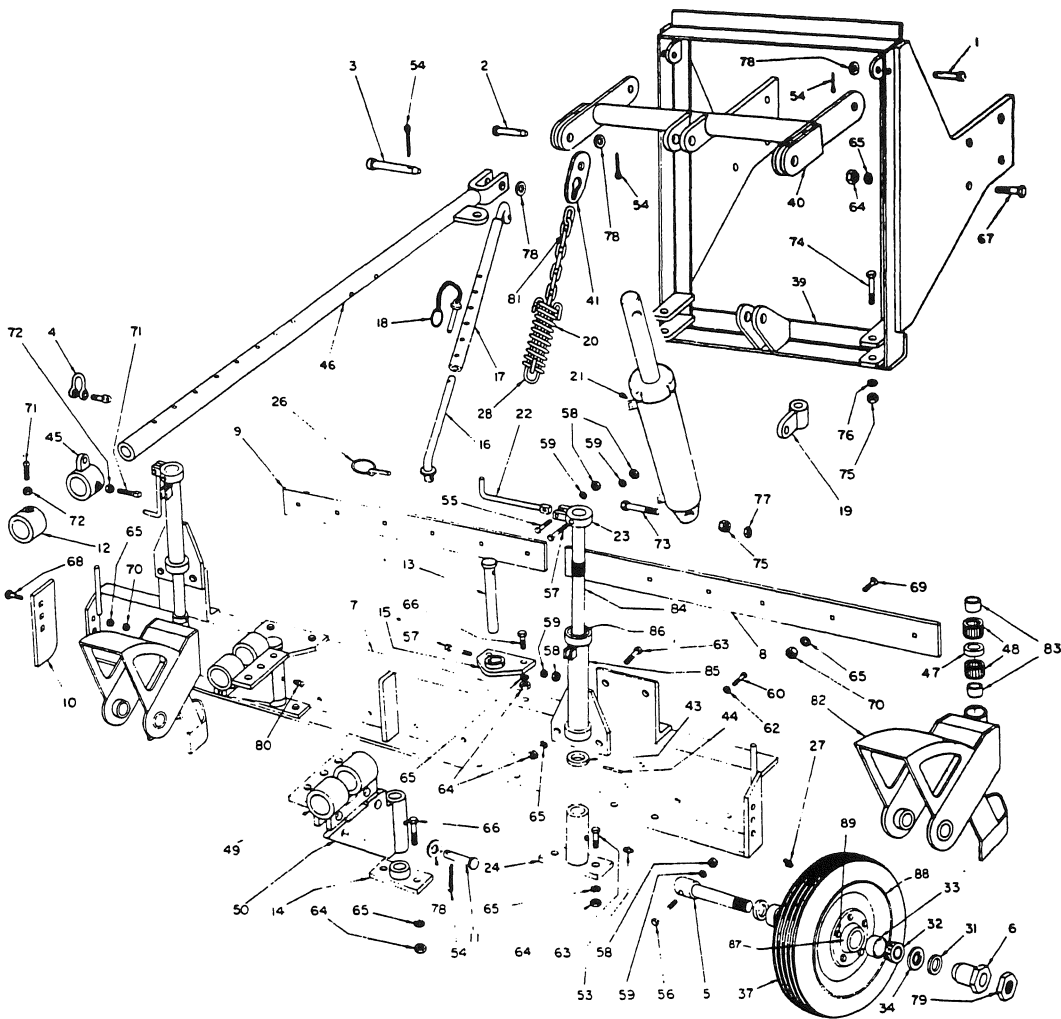

Figure 13

11. To disassemble the wheel axle and swivel housing assemblies, proceed as follows:

- a. Remove the pal nuts (79), adjusting sleeve (6) and spacer (31).
- b. Remove the hexagon head bolt (56), nut (58) and lockwasher (59) retaining the axle (5). Remove the axle, spacer, swivel housing (82) and wheel.
- c. Remove and inspect the two seals (34), bearing cones (32) and bearing cups (33) for serviceability. Replace faulty bearing and seals.
- d. Using a suitable drift, carefully remove the needle bearing inner races (83) and cages (48), together with the spacer (47). Inspect the bearings for serviceability. Replace faulty bearings.

12. Assembly and Installation (Fig. 13). To assemble the wheel axle and swivel housing assemblies, proceed as follows:

- a. Lubricate the bearing cones (32) and bearing cups (33) with grease. Carefully install the bearings into the wheel hub bore, followed by the two seals (34).
- b. Place the wheel at its position in the swivel housing (82), and install the axle (5) and spacer (31), taking care not to damage the seals. Retain the axle with the hexagon head bolt (56), nut (58) and lockwasher (59).
- c. Install the spacer. Install the adjusting sleeve (6), and tighten sufficiently to maintain free-running of the wheel bearings; then install and tighten the pal nut (79).
- d. Using a suitable drift, install the needle bearing inner races (83) and cages (48), together with the spacer (47).



## ATTACHMENTS

REF. NO.	DESCRIPTION	REF. NO.	DESCRIPTION
1	HEADED PIN	48	NEEDLE BEARING
2	HEADED PIN	49	TUBE & STRAP BRACKET
3	HEADED PIN	50	MAIN RIB PLATE
4	SHACKLE	53	GREASE FITTING
5	AXLE	54	1/4" X 1 1/2" LG. COTTER PIN
6	ADJUSTING SLEEVE	55	2" LG. HEX. HD. BOLT
7	MOLDBOARD ASSEMBLY	56	2 1/4" LG. HEX. HD. BOLT
8	7 FT. CUTTING EDGE	57	2 1/2" LG. HEX. HD. BOLT
9	6 FT. CUTTING EDGE	58	NUT
10	END SHOE	59	LOCKWASHER
11	HEADED PIN	60	1" LG. HEX. HD. BOLT
12	PULL COLLAR	62	LOCKWASHER
13	PIVOT PIN	63	1 1/2" LG. HEX. HD. BOLT
14	LOWER BRACKET	64	NUT
15	UPPER BRACKET	65	LOCKWASHER
16	INNER ARM	66	1 3/4" LG. HEX. HD. BOLT
17	OUTER ARM	67	2" LG. HEX. HD. BOLT
18	LOCK PIN	68	1 3/4" LG. CARRIAGE BOLT
19	SWIVEL	69	1 3/4" LG. CARRIAGE BOLT
20	SPRING	70	NUT
21	LIFT RAM	71	2" LG. SQUARE HEAD SET SCREW
22	HANDLE	72	JAM NUT
23	COLLAR	73	4" LG. HEX. HD. BOLT
24	LOWER SPINDLE GUIDE	74	5" LG. HEX. HD. BOLT
26	LINCH PIN	75	NUT
27	SPECIAL "LUBRIGUARD" GREASE FITTING	76	LOCKWASHER
28	HOOK BAR	77	PAL NUT
31	SPACER	78	FLATWASHER
32	CONE	79	PAL NUT
33	CUP	80	90 DEGREE GREASE FITTING
34	SEAL	81	CHAIN - 12 LINKS
37	TIRE & TUBE	82	SWIVEL HOUSING
39	A-FRAME	83	INNER RACE
40	LIFTING ARM	84	ADJUSTING SPINDLE
41	CHAIN PLATE	85	NUT HOUSING
43	POSITIONING WASHER	86	SCRAPER SEAL
44	ROLL PIN	87	HUB
45	LIFT COLLAR	88	RIM
46	PULL TUBE	89	BOLT
47	SPACER		

## KEY TO FIG. 13

13. To assemble the wheel adjustment spindle assembly, proceed as follows:
  - a. Install the lower spindle guide (24) and retain with the two hexagon head bolts (63), nuts (64) and lockwashers (65).
  - b. Install the nut housing (85), and retain with the two hexagon head bolts (63), nuts (64) and lockwashers (65).
  - c. Place the wheel and swivel housing assembly into position between the lower spindle guide and nut housing. Insert the adjusting spindle (84) into the nut housing. Before the spindle passes through the swivel housing bore, install the two positioning washers (43), one above and one below the bore.
  - d. Rotate the adjusting spindle in a clockwise direction until the roll pin holes in the spindle align with the holes in the positioning washers. Retain the washers with the roll pins (44).
14. To assemble the tube and strap bracket assembly, proceed as follows:
  - a. Install the upper bracket (15) and lower bracket (14), and retain with the hexagon head bolts (66), nuts (64) and lockwashers (65).
  - b. Place the main rib plate (50) into position, and install the pivot pin (13). Retain the pivot pin with the hexagon head bolt (57), nut (58) and lockwasher (59).

## ATTACHMENTS

- c. Install the tube and strap bracket (49), and retain with the headed pin (11). Install the flatwasher (78) and a new cotter pin (54).
15. Install the two lift collars (45) on the pull tubes (46). Insert the pull tubes into the tube and strap bracket assemblies; at the same time, introducing the pull collars (12).
16. Install the two chains (81) and shackles (4), and secure to the lift collars.
17. Install the adjustable drag link assembly, and secure with the two linch pins (26).
18. To install the A-frame (39) and components, proceed as follows:
  - a. Attach suitable lifting tackle to the A-frame, and hoist into position at the grader frame. Install the two adapter plates between the A-frame and the brackets. Retain the A-frame with with the eight hexagon head bolts (67), nuts (64) and lockwashers (65).
  - b. Place the lifting arm (40) into position, and retain to the A-frame with the two headed pins (1), flatwashers (78) and new cotter pins (54).
  - c. Install the cylinder (21) and retain with the two hexagon head bolts (73), nuts (75) and new pal nuts (77).
  - d. Install the two chain plates (41), and retain with the headed pins (2), flatwashers (78) and new cotter pins (54).
  - e. Install the two swivels (19), and retain with the hexagon head bolts (74), nuts (75) and lockwashers (76).
19. Attach suitable lifting tackle to the pull tubes, and place in position at the A-frame swivels. Retain the pull tubes with the headed pins (3), flatwashers (78) and new cotter pins (54).
20. Position the moldboard assembly in the working position, and secure the pull collars with the square head set screws (71) and jam nuts (72).

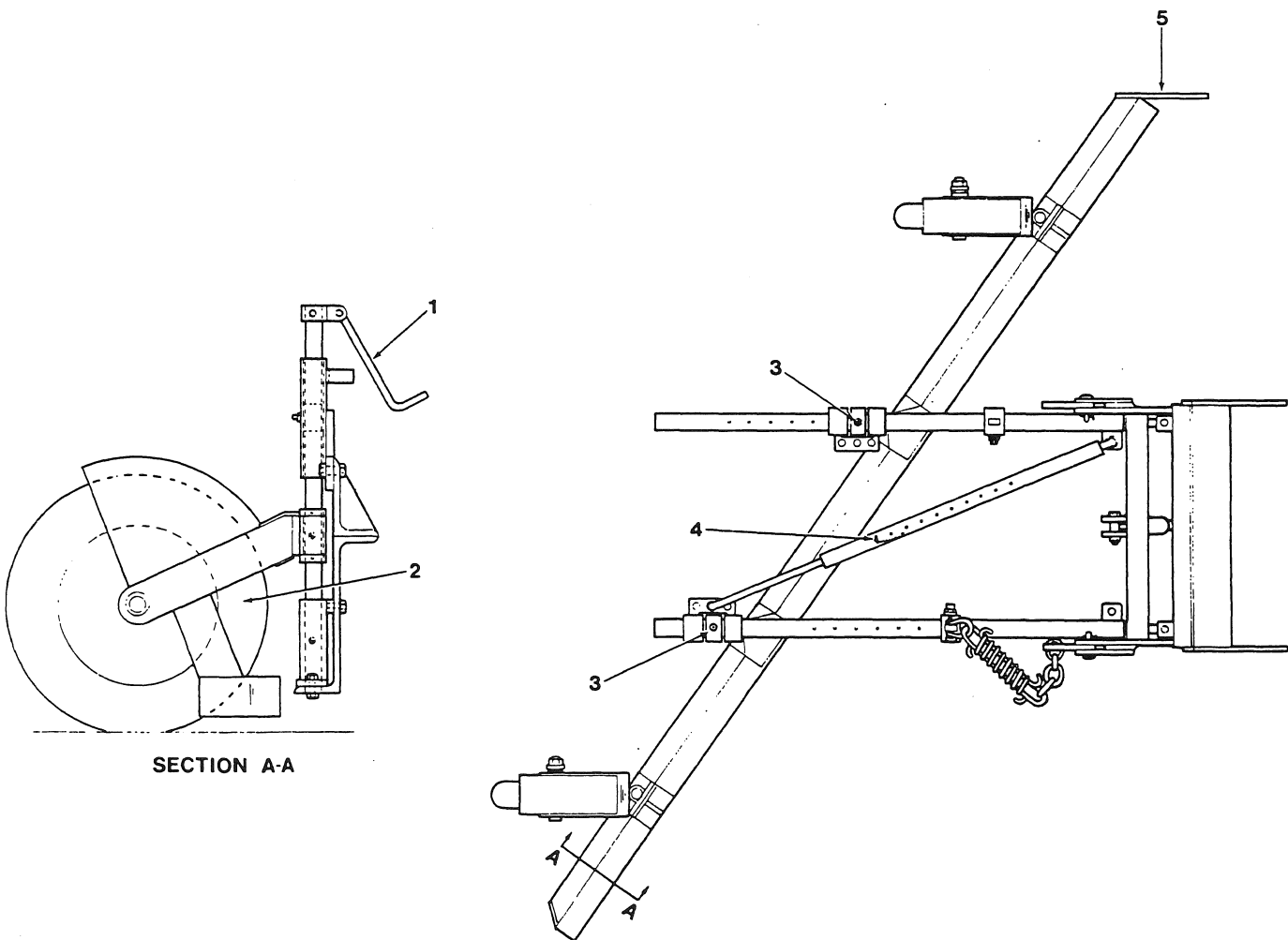

Figure 14

ATTACHMENTS

21. Arrange the lift collars in an offset configuration (refer to Fig. 14) and secure with the square head set screws (71) and jam nuts (72). Install the chains in the chain plates.
22. Disconnect the manifold valve supply hose at the pressure relief valve tee fitting. Re-connect the manifold valve supply hose to the pressure hose from the solenoid valve, at the union fitting.
23. Re-connect the hose from the solenoid valve to the pressure relief valve, and the hoses to the cylinder. Install the electrical connections to the solenoid valve.
24. Raise and lower the windrow eliminator, and ensure that no binding occurs in the linkage.
25. Adjustments (Fig. 14). Various adjustments are available depending upon the prevailing working conditions. The adjustments are as follows:
  - a. Moldboard Height. Remove the adjusting spindle handle (1) from the clip, and turn the handle to raise or lower the wheel (2). The moldboard will be raised or lowered accordingly. Secure the handle in the clip. Repeat for the other wheel.
  - b. Moldboard Angle. The moldboard angle can be varied by raising the attachment, releasing the pull collar set screws (3) and removing the adjusting link assembly lock pin (4). Move the moldboard to the desired angle, install the lock pin and secure the set screws. If the moldboard angle has been adjusted from one extreme to the other, remove the three carriage bolts, nuts and lockwashers retaining the end shoe (5) and install on the opposite end of the moldboard. Also, alternate the offset position of the lift collars, and adjust the chain tension accordingly.
  - c. Moldboard Reach. The complete attachment can be angled to either side of the grader by releasing the adjusting link assembly lock pin (4) and extending or retracting the inner arm inside the outer arm until the desired amount of reach is obtained. Install the lock pin. The pull tubes will remain parallel.
26. Worn edges can be replaced by removing the required quantity of carriage bolts, nuts and lockwashers, then removing the edges.
27. Install new edges, and retain with the carriage bolts, nuts and lockwashers.

FRONT MOUNTED WING

1. Removal and Disassembly (Figs. 15, 16 and 17).

WARNING:

Before disconnecting any hydraulic hoses or fittings, lower the wing blade onto the ground.

The rear lift and slide cylinders are controlled by a double bank solenoid valve mounted on the rear mast, and the front lift cylinder is controlled by a single bank solenoid valve mounted on the front mast.

2. Hydraulic oil is transmitted from the primary hydraulic circuit to the double bank solenoid valve; then directed to the single bank solenoid valve and the manifold valve.
3. When removing the rear mast, disconnect both hoses at the solenoid valve. Plug the valve fittings.

NOTE:

A plumbing revision incorporates a tube at one of the valve connections:- effective serial number 9884 onwards.

Remove one hose (hose and tube for the latest configuration) at the tube on the frame. Loop the other hose, and connect to the tube on the frame; thus allowing oil to flow to the front mast solenoid valve.

4. When removing the front mast, disconnect both hoses at the solenoid valve. Plug the valve fittings. Remove the hose at the tube leading to the manifold valve. Loop the other hose, and connect to the tube leading to the manifold valve.
5. Remove the electrical connections to the solenoid valves, and temporarily attach the wire harnesses to the grader frame.

6. WARNING:

It is essential that reliable, heavy-duty lifting tackle is available when removing the front mounted wing masts and blade.

Attach the lifting tackle to the wing blade (90, 92, 114 or 115, Fig. 15). Remove the two hexagon head bolts (94, Fig. 15), nuts (96, Fig. 15) and lockwashers (95, Fig. 15) retaining the knuckles (76, Fig. 15) to the wing blade. Remove and discard the cotter

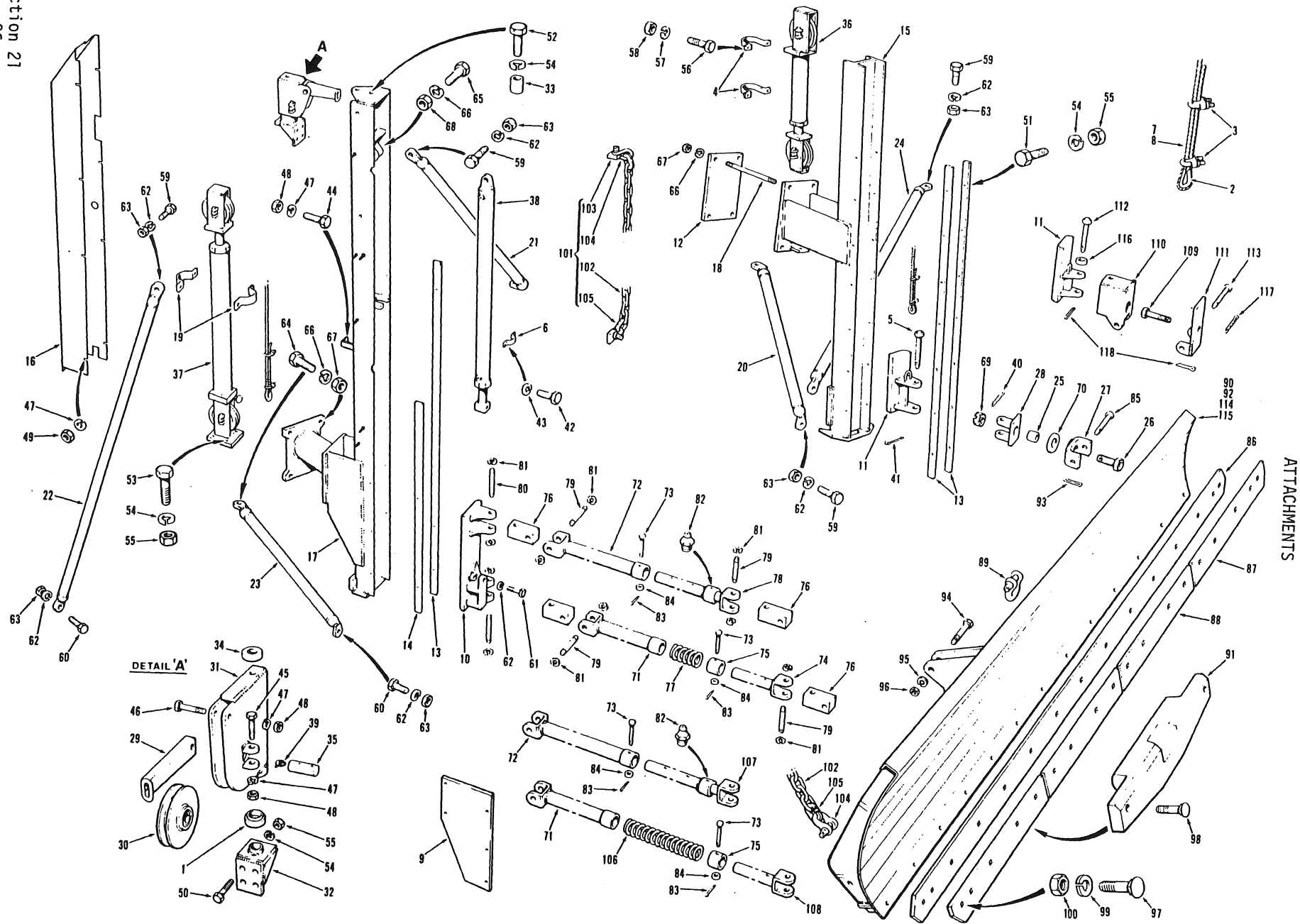

Figure 15

REF. NO.	DESCRIPTION	REF. NO.	DESCRIPTION	REF. NO.	DESCRIPTION
	FRONT & REAR MAST INSTALLATION	44	1 1/2" LG. HEX. HD. BOLT		WING INSTALLATION - STANDARD
1	THRUST BEARING	45	2" LG. HEX. HD. BOLT	85	PIN
2	THIMBLE	46	2 1/2" LG. HEX. HD. BOLT	86	WING EDGE
3	CABLE CLAMP	47	LOCKWASHER	87	WING EDGE - OUTER - CARBIDE TIPPED
4	CLAMP	48	NUT	88	WING EDGE - INNER - CARBIDE TIPPED
5	PIN	49	NUT	39	SHACKLE
6	CLAMP	50	1 1/2" LG. HEX. HD. BOLT	90	WING - DRILLED FOR STANDARD EDGE
7	CABLE 25' LG. - FRONT MAST	51	1 3/4" LG. HEX. HD. BOLT	91	WING SHOE
8	CABLE 52' LG. - REAR MAST	52	2 1/4" LG. HEX. HD. BOLT	92	WING - DRILLED FOR CARBIDE EDGE
9	ICE SHIELD - LOWER	53	2" LG. HEX. HD. BOLT	93	COTTER PIN
10	SLIDE ASSY. - REAR MAST	54	LOCKWASHER	94	5 1/2" LG. HEX. HD. BOLT
11	SLIDE ASSY. - FRONT MAST	55	NUT	95	LOCKWASHER
12	MOUNTING BRACKET	56	1 3/4" LG. HEX. HD. BOLT	96	NUT
13	SLIDE GUIDE - LONG	57	LOCKWASHER	97	2" LG. PLOW BOLT
14	SLIDE GUIDE - SHORT	58	NUT	98	3 1/2" LG. PLOW BOLT
15	FRONT MAST	59	2 1/2" LG. HEX. HD. BOLT	99	LOCKWASHER
16	ICE SHIELD	60	3" LG. HEX. HD. BOLT	100	NUT
17	REAR MAST	61	4" LG. HEX. HD. CAPSCREW	101	WING SAFETY CHAIN ASSY.
18	TIE BOLT	62	LOCKWASHER	102	CHAIN 33" LG.
19	CLAMP	63	NUT	103	LUG
20	FRONT MAST BRACE - LOWER	64	3 1/2" LG. HEX. HD. CAPSCREW	104	SHACKLE
21	REAR MAST BRACE - FWD.	65	4" LG. HEX. HD. BOLT	105	SPLIT LINK
22	REAR MAST BRACE - AFT.	66	LOCKWASHER		PARTS APPLICABLE FOR OPTIONAL TRIP WING INSTALLATION
23	REAR MAST BRACE - LOWER	67	NUT	106	SPRING
24	FRONT MAST BRACE - FWD.	68	NUT	107	INNER SLEEVE - UPPER ARM
25	SPACER	69	JAM NUT	108	INNER SLEEVE - LOWER ARM
26	SWIVEL PIN	70	FLATWASHER	109	WING BOLT
27	MOUNTING SWIVEL			110	SWIVEL ASSY.
28	HINGE		STAND-OFF ARMS INSTALLATION-STANDARD	111	HINGE PLATE
29	CABLE GUIDE			112	SWIVEL PIN
30	SHEAVE ASSY.	71	OUTER SLEEVE - LOWER ARM	113	PIVOT PLATE PIN
31	SWIVEL HOUSING	72	OUTER SLEEVE - UPPER ARM	114	TRIP WING - DRILLED FOR STD. EDGE
32	BRACKET	73	SHEAR PIN	115	TRIP WING - DRILLED FOR CARBIDE EDGES
33	SPACER BUSHING	74	INNER SLEEVE - LOWER ARM	116	SPACER WASHER
34	SPACER COLLAR	75	COLLAR	117	COTTER PIN
35	SHEAVE PIN	76	KNUCKLE	118	COTTER PIN
36	LIFT CYLINDER - FRONT MAST	77	SPRING		
37	LIFT CYLINDER - REAR MAST	78	INNER SLEEVE - UPPER ARM		
38	SLIDE CYLINDER	79	1" DIA. X 5" LG. PIN		
39	45° GREASE FITTING	80	1" DIA. X 6" LG. PIN		
40	COTTER PIN	81	KLIPRING FASTENER		
41	COTTER PIN	82	STRAIGHT GREASE FITTING		
42	1" LG. HEX. HD. BOLT	83	COTTER PIN		
43	LOCKWASHER	84	FLATWASHER		

ATTACHMENTS

## ATTACHMENTS

pin (93, Fig. 15) retaining the pin (85, Fig. 15), and remove the pin. Disconnect the shackle (89, Fig. 15) and remove the cable (8, Fig. 15). Hoist the blade away from the grader. Remove the lifting tackle.

### NOTE:

For machines equipped with the optional trip wing installation, remove and discard the cotter pin (118, Fig. 15) retaining the pivot plate pin (113, Fig. 15), and remove the pin. Remove and discard the cotter pin (117, Fig. 15) retaining the hexagon head bolt (109, Fig. 15). Remove the bolt and hinge plate (111, Fig. 15).

7. Attach the lifting tackle to the front mast (15, Fig. 15). Remove the hexagon head bolts (59, Fig. 15), nuts (63, Fig. 15) and lockwashers (62, Fig. 15) retaining the lower front mast brace (20, Fig. 15) and forward front mast brace (24, Fig. 15). Remove the braces.
8. Remove the four nuts (67, Fig. 15) and lockwashers (66, Fig. 15) retaining the front mast to the mounting bracket tie bolts (18, Fig. 15). Carefully hoist the front mast away from the grader. Remove the mounting bracket (12, Fig. 15) and tie bolts. Remove the lifting tackle.
9. Remove the kliprings (81, Fig. 15) securing the two attachment pins (80, Fig. 15) connecting the knuckles (76, Fig. 15) to the rear mast slide (10, Fig. 15). Remove both the upper and lower stand-off arms.
10. Attach the lifting tackle to the rear mast (17, Fig. 15). Remove the hexagon head bolts (59, Fig. 15), nuts (63, Fig. 15) and lockwashers (62, Fig. 15) retaining the forward rear mast brace (21, Fig. 15). Remove the hexagon head bolts (59 and 60, Fig. 15), nuts (63, Fig. 15) and lockwashers (62, Fig. 15) retaining the aft rear mast brace (22, Fig. 15). Remove the hexagon head bolts (60 and 64, Fig. 15), nuts (63 and 67, Fig. 15) and lockwashers (67 and 66, Fig. 15) retaining the lower rear mast brace (23, Fig. 15). Remove the braces.
11. Remove the four hexagon head bolts (64, Fig. 15), nuts (67, Fig. 15) and lockwashers (66, Fig. 15) retaining the rear mast support to the grader frame. Carefully hoist the rear mast away from the grader. Remove the lifting tackle.
12. To disassemble the front mast and components, proceed as follows:
  - a. Remove the cable clamps (3, Fig. 15) securing the cable ends (7, Fig. 15). Release the two thimbles (2, Fig. 15), and remove the cable.
  - b. Attach lifting tackle to the lift cylinder (36, Fig. 15). Remove the cylinder plumbing. Remove the four hexagon head bolts (56, Fig. 15), nuts (58, Fig. 15) and lockwashers (57, Fig. 15) retaining the two clamps (4, Fig. 15). Remove the clamps and cylinder.
  - c. Remove the hexagon head bolts (3 and 19, Fig. 16), nuts (1 and 17, Fig. 16) and lockwashers (2 and 18, Fig. 16) retaining the sheave pins (7 and 15, Fig. 16). Remove the sheave pins and sheaves (5, 6 and 16, Fig. 16). Remove the two hexagon head capscrews (11, Fig. 16), lockwashers (12, Fig. 16) and flatwashers (13, Fig. 16), and remove the ice scraper (10, Fig. 16).
  - d. Remove the seven hexagon head bolts (51, Fig. 15), nuts (55, Fig. 15) and lockwashers (54, Fig. 15) retaining each slide guide (13, Fig. 15), and remove the guides.
  - e. Remove and discard the cotter pin (41, Fig. 15) retaining the pin (5, Fig. 15), and remove the hinge assembly from the slide (11, Fig. 15). Remove the slide.
  - f. Remove and discard the cotter pin (40, Fig. 15) retaining the hexagon head bolt (26, Fig. 15). Remove the bolt and jam nut (69, Fig. 15), and separate the hinge (28, Fig. 15), spacer (25, Fig. 15), flatwasher (70, Fig. 15) and mounting swivel (27, Fig. 15).
13. To disassemble the rear mast and components, proceed as follows:
  - a. Remove the eight nuts (49, Fig. 15) and lockwashers (47, Fig. 15) retaining the ice shield (16, Fig. 15), and remove the ice shield.
  - b. Remove the cable clamps (3, Fig. 15) securing the cable ends (8, Fig. 15). Release the two thimbles (2, Fig. 15), and remove the cable.

### NOTE:

For machines equipped with the optional trip wing installation, remove and discard the cotter pin (118, Fig. 15) retaining the swivel pin (112, Fig. 15). Remove the swivel pin, spacer washer (116, Fig. 15) and swivel assembly (110, Fig. 15). Remove the slide (11, Fig. 15).

ATTACHMENTS

- c. Remove the two hexagon head bolts (44, Fig. 15), nuts (48, Fig. 15) and lockwashers (47, Fig. 15) retaining the two clamps (19, Fig. 15).
- d. Attach lifting tackle to the lift cylinder (37, Fig. 15). Remove the cylinder plumbing. Remove the four hexagon head bolts (53, Fig. 15), nuts (55, Fig. 15) and lockwashers (54, Fig. 15) retaining the cylinder base plate. Remove the cylinder.

- e. Remove the hexagon head bolts (3 and 18, Fig. 17), nuts (1 and 16, Fig. 17) and lockwashers (2 and 17, Fig. 17) retaining the sheave pins (6 and 13, Fig. 17). Remove the sheave pins and sheaves (5 and 12, Fig. 17). Remove the two hexagon head capscrews (11, Fig. 17), lockwashers (10, Fig. 17) and flatwashers (9, Fig. 17), and remove the ice scraper (8, Fig. 17).

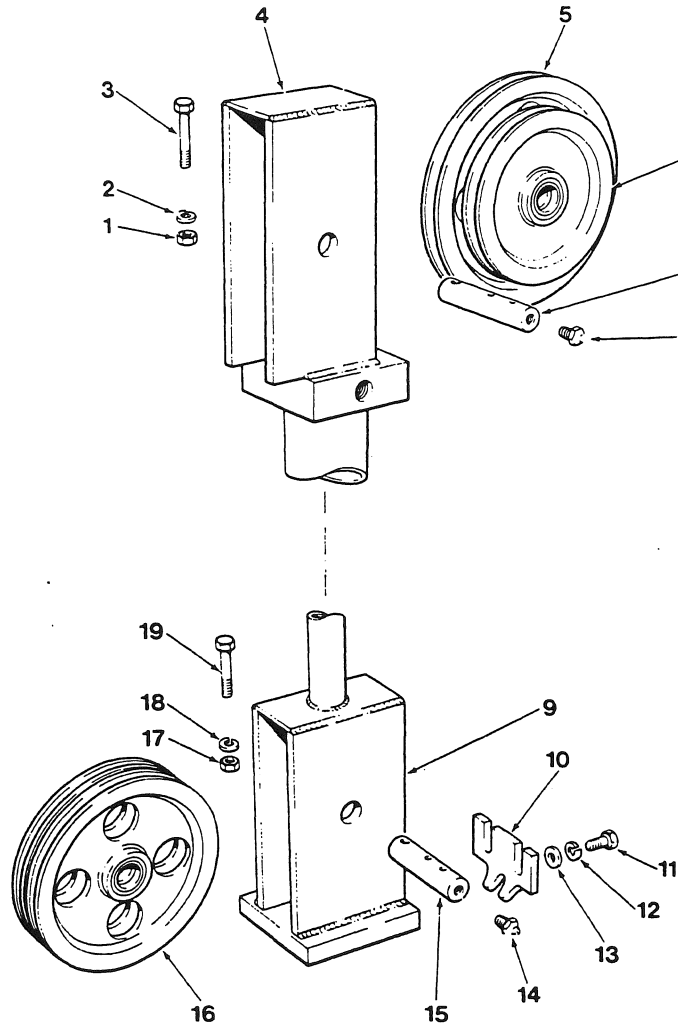

Figure 16

REF. NO.	DESCRIPTION	REF. NO.	DESCRIPTION
1	NUT	11	1" LG. HEX. HD. CAPSCREW
2	LOCKWASHER	12	LOCKWASHER
3	2 1/4" LG. HEX. HD. BOLT	13	FLATWASHER
4	UPPER SHEAVE HOUSING	14	STRAIGHT GREASE FITTING
5	SHEAVE - 9 1/2" O.D.	15	SHEAVE PIN
6	SHEAVE - 7" O.D.	16	SHEAVE - 8 1/2" O.D.
7	SHEAVE PIN	17	NUT
8	STRAIGHT GREASE FITTING	18	LOCKWASHER
9	LOWER SHEAVE HOUSING	19	2 1/4" LG. HEX. HD. BOLT
10	ICE SCRAPER		

KEY TO FIG. 16

## ATTACHMENTS

- f. Remove the hexagon head capscrew (61, Fig. 15) and lockwasher (62, Fig. 15) retaining the slide cylinder piston rod to the slide. Remove the cylinder plumbing. Remove the hexagon head capscrews (42, Fig. 15) and lockwashers (43, Fig. 15) retaining the clamp (6, Fig. 15). Remove the hexagon head bolt (65, Fig. 15), nut (68, Fig. 15) and lockwasher (66, Fig. 15) retaining the slide cylinder (38, Fig. 15) to the rear mast lugs. Remove the cylinder.
  - g. Remove the twelve hexagon head bolts (51, Fig. 15), nuts (55, Fig. 15) and lockwashers (54, Fig. 15) retaining the long and short slide guides (13 and 14, Fig. 15), and remove the guides. Remove the slide.
  - h. Remove the hexagon head capscrew (52, Fig. 15), lockwasher (54, Fig. 15) and spacer washer (33, Fig. 15). Remove the four hexagon head bolts (50, Fig. 15), nuts (55, Fig. 15) and lockwashers (54, Fig. 15) retaining the swivel housing bracket (32, Fig. 15). Remove the bracket, together with the swivel housing assembly, spacer collar (34, Fig. 15) and thrust bearing (1, Fig. 15). Inspect the thrust bearing for serviceability. Replace a faulty bearing.
  - i. Remove the hexagon head bolt (46, Fig. 15), nut (48, Fig. 15) and lockwasher (47, Fig. 15) securing the cable guide (29, Fig. 15), and remove the guide.
  - j. Remove the hexagon head bolt (45, Fig. 15), nut (48, Fig. 15) and lockwasher (47, Fig. 15) retaining the sheave pin (35, Fig. 15). Remove the sheave pin and sheave (30, Fig. 15) from the swivel housing (31, Fig. 15).
  - k. All D700 series graders before serial number 9950 only:

Remove the hardware retaining the ice shield (9, Fig. 15) to the mast, and remove the ice shield.
  - l. For machines equipped with the optional wing safety chain assembly (101, Fig. 15), remove the two shackles (104, Fig. 15) at the lugs (103, Fig. 15), and remove the chain (102, Fig. 15). The chain can also be removed at the two split links (105, Fig. 15).
14. To disassemble the upper and lower stand-off arms, proceed as follows:
    - a. Remove the kliprings (81, Fig. 15) securing the attachment pins (79, Fig. 15) connecting the knuckles (76, Fig. 15) to the inner sleeves (78 and 74, or 107 and 108, Fig. 15) and the outer sleeves (72 and 71, Fig. 15).
    - b. Remove and discard the cotter pins (83, Fig. 15) retaining the shear pins (73, Fig. 15). Remove the shear pins and flatwashers (84, Fig. 15), and separate the inner and outer sleeves.
    - c. Remove the collar (75, Fig. 15) and spring (77 or 106, Fig. 15).
  15. Assembly and Installation (Figs. 15, 16 and 17). To assemble the upper and lower stand-off arms, proceed as follows:
    - a. Install the collar (75, Fig. 15) and spring (77 or 106, Fig. 15) onto the lower stand-off arm inner sleeves (74 or 108, Fig. 15). Retain the collar with the shear pin (73, Fig. 15), flatwasher (84, Fig. 15) and a new cotter pin (83, Fig. 15).
    - b. Insert the inner sleeves into the outer sleeves (72 and 71, Fig. 15). Retain the inner and outer sleeves of the upper stand-off arms with the shear pin (73, Fig. 15), flatwasher (84, Fig. 15) and a new cotter pin (83, Fig. 15).
    - c. Install the knuckles (76, Fig. 15), and retain with the attachment pins (79, Fig. 15). Secure the attachment pins with the kliprings (81, Fig. 15).
  16. To assemble the rear mast and components, proceed as follows:
    - a. Install the sheave (30, Fig. 15) into the swivel housing (31, Fig. 15), and retain with the sheave pin (35, Fig. 15). Retain the sheave pin with the hexagon head bolt (45, Fig. 15), nut (48, Fig. 15) and lockwasher (47, Fig. 15).
    - b. Install the cable guide (29, Fig. 15), and secure with the hexagon head bolt (46, Fig. 15), nut (48, Fig. 15) and lockwasher (47, Fig. 15).
    - c. Install the swivel housing bracket (32, Fig. 15), and retain with the four hexagon head bolts (50, Fig. 15), nuts (55, Fig. 15) and lockwashers (54, Fig. 15).
    - d. Install the swivel housing assembly, together with the thrust bearing (1, Fig. 15) and spacer collar (34, Fig. 15). Retain the swivel housing with the hexagon head capscrew (52, Fig. 15), lockwasher (54, Fig. 15) and spacer washer (33, Fig. 15).
    - e. Install the slide (10, Fig. 15). Install the long and short slide guides (13 and 14, Fig. 15), and retain with the twelve hexagon head bolts (51, Fig. 15), nuts (55, Fig. 15) and lockwashers (54, Fig. 15).
    - f. Place the slide cylinder (38, Fig. 15) into position on the rear mast, and retain to the lugs with the hexagon



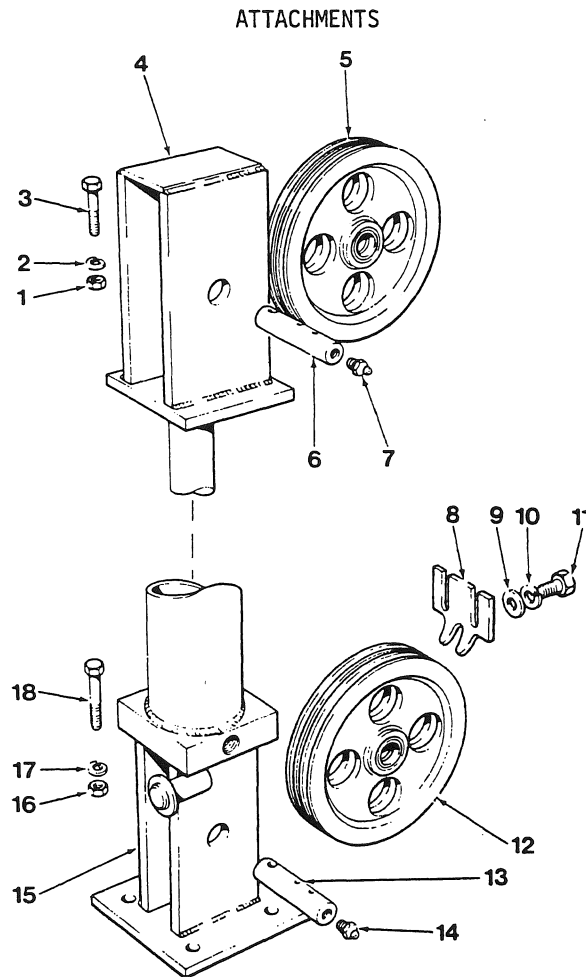

Figure 17

REF. NO.	DESCRIPTION	REF. NO.	DESCRIPTION
1	NUT	10	LOCKWASHER
2	LOCKWASHER	11	1" LG. HEX. HD. CAPSCREW
3	2 1/4" LG. HEX. HD. BOLT	12	SHEAVE - 8 1/2" O.D.
4	UPPER SHEAVE HOUSING	13	SHEAVE PIN
5	SHEAVE - 8 1/2" O.D.	14	STRAIGHT GREASE FITTING
6	SHEAVE PIN	15	LOWER SHEAVE HOUSING
7	STRAIGHT GREASE FITTING	16	NUT
8	ICE SCRAPER	17	LOCKWASHER
9	FLATWASHER	18	2 1/4" LG. HEX. HD. BOLT

KEY TO FIG. 17

- head bolt (65, Fig. 15), nut (68, Fig. 15) and lockwasher (66, Fig. 15). Install the clamp (6, Fig. 15), and retain with the two hexagon head cap-screws (42, Fig. 15) and lockwashers (43, Fig. 15). Retain the slide cylinder piston rod to the slide with the hexagon head cap screw (61, Fig. 15) and lockwasher (62, Fig. 15). Install the cylinder plumbing.
- g. Install the sheaves (5 and 12, Fig. 17) into the sheave housings, and retain with the sheave pins (6 and 13, Fig. 17). Retain the pins with the
- hexagon head bolts (3 and 18, Fig. 17), nuts (1 and 16, Fig. 17) and lockwashers (2 and 17, Fig. 17). Install the ice scraper (8, Fig. 17), and retain with the two hexagon head cap-screws (11, Fig. 17), lockwashers (10, Fig. 17) and flatwashers (9, Fig. 17).
- h. Install the lift cylinder (37, Fig. 15), and retain the base plate with the four hexagon head bolts (53, Fig. 15), nuts (55, Fig. 15) and lockwashers (54, Fig. 15). Install the cylinder plumbing.

## ATTACHMENTS

- i. Install the clamps (19, Fig. 15), and retain with the two hexagon head bolts (44, Fig. 15), nuts (48, Fig. 15) and lockwashers (47, Fig. 15).
- j. Install a thimble (2, Fig. 15) at one end of the cable (8, Fig. 15), and install on the anchor pin. Install two cable clamps (3, Fig. 15) (nuts on the opposite side to the cable dead end), and torque-tighten the nuts to 65 ft/lb (8,9 kg/m).
- k. Thread the cable around the sheaves as shown in Fig. 18. Install a thimble on the other end of the cable. Install the cable clamps (nuts on the opposite side to the cable dead end), and torque-tighten the nuts to 65 ft/lb (8,9 kg/m).

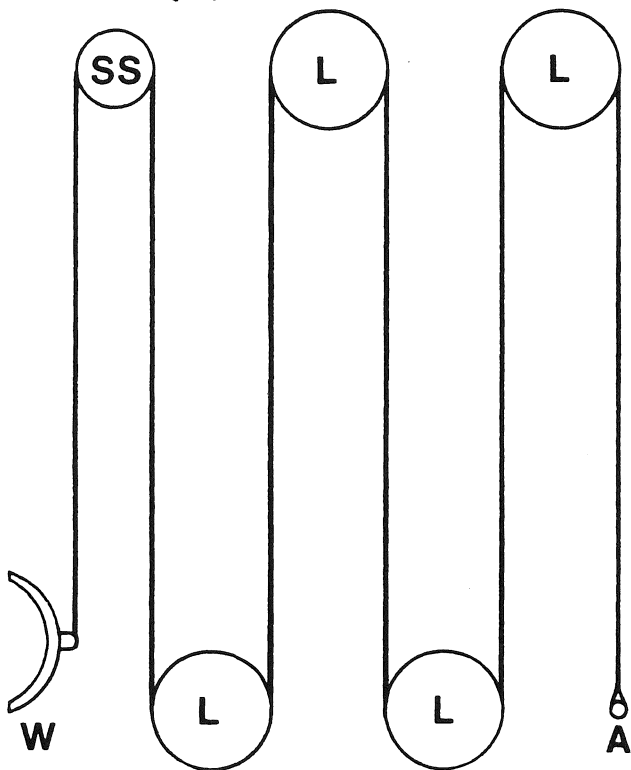

A	ANCHOR
SS	SWIVEL SHEAVE
L	LARGE SHEAVE
W	WING BLADE

Figure 18

- l. Install the ice shield (16, Fig. 15), and retain to the mast with the eight nuts (49, Fig. 15) and lockwashers (47, Fig. 15).
- m. All D700 series graders before serial number 9950 only:

Install the ice shield (9, Fig. 15) to the mast, and retain with the hardware.

- n. For machines equipped with the optional wing safety chain assembly (101, Fig. 15), install the chain (102, Fig. 15) and secure either at the two split links (105, Fig. 15), or the two shackles (104, Fig. 15) at the lugs (103, Fig. 15).

17. To assemble the front mast and components, proceed as follows:

- a. Install the mounting swivel (27, Fig. 15), flatwasher (70, Fig. 15), spacer (25, Fig. 15) and hinge (28, Fig. 15) onto the hexagon head bolt (26, Fig. 15). Retain the bolt with the jam nut (69, Fig. 15), and secure with a new cotter pin (40, Fig. 15).

### NOTE:

For machines equipped with the optional trip wing installation, install the swivel assembly (110, Fig. 15) to the slide (11, Fig. 15), and retain with the swivel pin (112, Fig. 15) and spacer washer (116, Fig. 15). Secure the swivel pin with a new cotter pin (118, Fig. 15).

- b. Install the mounting swivel assembly onto the slide (11, Fig. 15), and retain with the pin (5, Fig. 15). Secure the pin with a new cotter pin (41, Fig. 15).
- c. Place the slide assembly into position in the mast channel. Install the two slide guides (13, Fig. 15), and retain with the fourteen hexagon head bolts (51, Fig. 15), nuts (55, Fig. 15) and lockwashers (54, Fig. 15).
- d. Install the sheaves (5, 6 and 16, Fig. 16) and sheave pins (7 and 15, Fig. 16). Retain the sheave pins with the hexagon head bolts (3 and 19, Fig. 16), nuts (1 and 17, Fig. 16) and lockwashers (2 and 18, Fig. 16). Install the ice scraper (10, Fig. 16), and retain with the two hexagon head capscrews (11, Fig. 16), lockwashers (12, Fig. 16) and flatwashers (13, Fig. 16).
- e. Attach suitable lifting tackle to the lift cylinder (36, Fig. 15) and place into position on the mast. Install the clamps (4, Fig. 15), and retain with the four hexagon head bolts (56, Fig. 15), nuts (58, Fig. 15) and lockwashers (57, Fig. 15). Remove the lifting tackle. Install the cylinder plumbing.
- f. Install a thimble (2, Fig. 15) at one end of the cable (7, Fig. 15), and install on the anchor pin. Install

## ATTACHMENTS

- the cable clamps (3, Fig. 15) (nuts on the opposite side to the cable dead end), and torque-tighten the nuts to 65 ft/lb (8,9 kg/m).
- g. Thread the cable around the sheaves as shown in Fig. 19. Install a thimble at the other end of the cable, and install on the slide U-bolt. Install two cable clamps (nuts on the opposite side to the cable dead end), and torque-tighten the nuts to 65 ft/lb (8,9 kg/m).

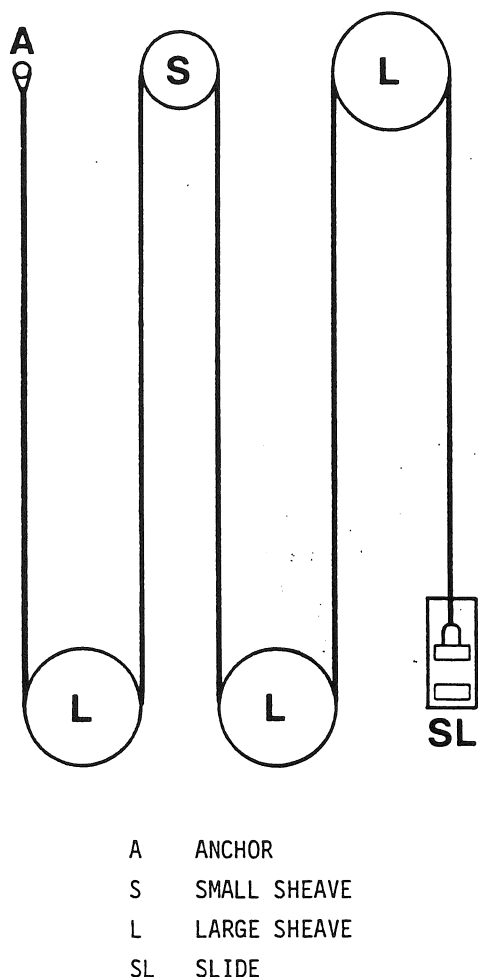

Figure 19

18. **WARNING:**  
It is essential that reliable heavy-duty lifting tackle is available when installing the front mounted wing masts and blade.

Attach the lifting tackle to the rear mast (17, Fig. 15), and place into position at the grader frame. Install the four hexagon head bolts (64, Fig. 15), nuts (67, Fig. 15) and lockwashers (66, Fig. 15) retaining the mast support.

19. Install the forward rear mast brace (21, Fig. 15), and retain with the hexagon head bolts (59, Fig. 15), nuts (63, Fig. 15) and lockwashers (62, Fig. 15). Install the aft rear mast brace (22, Fig. 15), and retain with the hexagon head bolts (59 and 60, Fig. 15), nuts (63, Fig. 15) and lockwashers (62, Fig. 15). Install the lower rear mast brace (23, Fig. 15), and retain with the hexagon head bolts (60 and 64, Fig. 15), nuts (63 and 67, Fig. 15) and lockwashers (67 and 66, Fig. 15).
20. Place the upper and lower stand-off arms into position at the rear mast slide (10, Fig. 15). Connect the knuckles (76, Fig. 15) to the slide, and retain with the two attachment pins (80, Fig. 15). Secure the pins with the kliprings (81, Fig. 15). Remove the lifting tackle.
21. Attach the lifting tackle to the front mast (15, Fig. 15), and place into position at the grader frame. Install the mounting bracket (12, Fig. 15) and tie bolts (18, Fig. 15). Install the four nuts (67, Fig. 15) and lockwashers (66, Fig. 15).
22. Install the forward front mast brace (24, Fig. 15) and lower front mast brace (20, Fig. 15), and retain with the hexagon head bolts (59, Fig. 15), nuts (63, Fig. 15) and lockwashers (62, Fig. 15). Remove the lifting tackle.
23. Attach the lifting tackle to the wing blade (90, 92, 114 or 115, Fig. 15). Place into position at the upper and lower stand-off arms, and retain with the hexagon head bolts (94, Fig. 15), nuts (96, Fig. 15) and lockwashers (95, Fig. 15). Install the pin (85, Fig. 15) to connect the wing blade and front mast swivel. Secure the pin with a new cotter pin (93, Fig. 15). Install the cable (8, Fig. 15), and retain with the shackle (89, Fig. 15).

**NOTE:**

For machines equipped with the optional trip wing installation, install the hinge plate (111, Fig. 15), and retain with the hexagon head bolt (109, Fig. 15). Secure the bolt with a new cotter pin (117, Fig. 15). Connect the swivel (110, Fig. 15) to the hinge plate with the pivot plate pin (113, Fig. 15). Secure the pin with a new cotter pin (118, Fig. 15).

Remove the lifting tackle.

## ATTACHMENTS

24. After installing the front mast, disconnect the hose at the tube leading to the manifold valve. Install the original hose at the tube leading to the manifold valve. Re-connect both hoses to the solenoid valve.
25. After installing the rear mast, disconnect the hose at the tube on the frame. Install the original hose (hose and tube for the latest configuration) at the tube on the frame. Re-connect both hoses to the solenoid valve.
26. Install the electrical connections to the solenoid valve.
27. Adjustments (Figs. 15 and 20). The amount of wing blade angle and pitch can be varied by adjusting the inner sleeves within the outer sleeves of the stand-off arms. Remove the cotter pins and shear pins, adjust the inner sleeves, and install the shear pins in the nearest alternative hole. Secure with the cotter pins (2, Fig. 20). Wing blade front end height adjustment is achieved by selecting an alternative hole in the blade strengthening plate (1, Fig. 20).
28. Worn edges (86, 87 or 88, Fig. 15) can be replaced by removing the required quantity of carriage bolts (97, Fig. 15), nuts (100, Fig. 15) and lockwashers (99, Fig. 15), then removing the edges.
29. Install new edges, and retain with the carriage bolts, nuts and lockwashers.
30. Worn wing shoes (91, Fig. 15) can be replaced by removing the required quantity of carriage bolts (98, Fig. 15), nuts (100, Fig. 15) and lockwashers (99, Fig. 15), then removing the shoes.
31. Install new shoes, and retain with the carriage bolts, nuts and lockwashers.

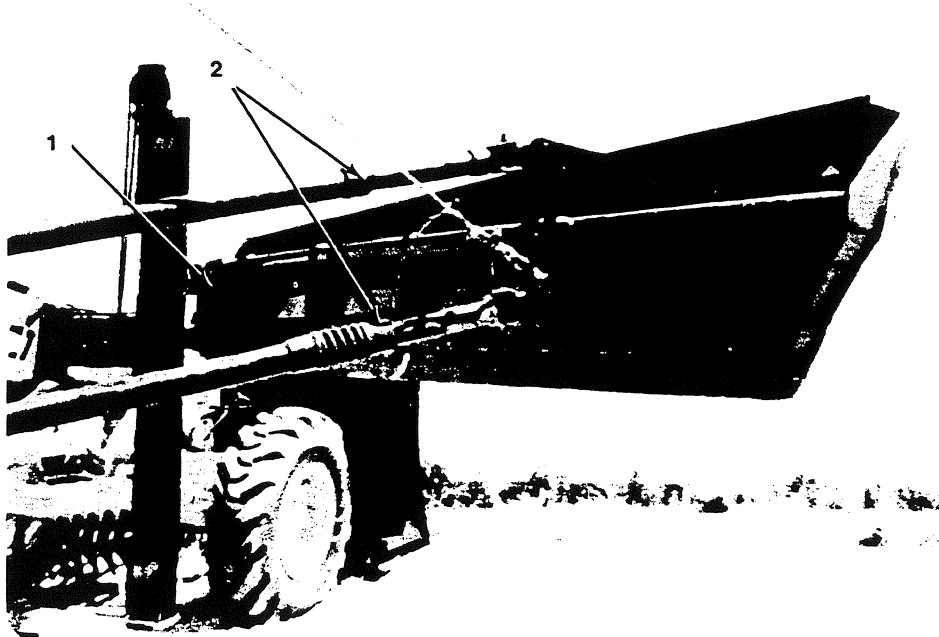

Figure 20

### REAR MOUNT WING

1. Removal and Disassembly (Figs. 21, 22 and 23).

#### WARNING:

Before disconnecting any hydraulic hoses or fittings, lower the wing blade onto the ground.

D700 series graders:- effective serial numbers up to 9007, 9011 to 9026, 9029, 9031 to 9049, 9051 to 9057 and 9098 to 9107:

2. The rear lift and slide cylinders, and front lift cylinder are controlled by a triple bank solenoid valve mounted on the rear mast.
2. Hydraulic oil is transmitted from the primary hydraulic circuit to the triple bank solenoid valve; then directed to the manifold valve.
3. When removing the rear mast, disconnect the supply and return hoses at the solenoid valve. Plug the valve fittings. Remove one hose at the tee fitting. Loop the other hose, and connect to the tee fitting; thus allowing oil to flow to the manifold valve.

## ATTACHMENTS

4. When removing the front mast, disconnect both hoses at the cylinder tube fittings. Plug the tube fittings. Remove one hose at the tube on the frame. Loop the other hose, and connect to the tube on the frame.

5. Remove the electrical connections to the solenoid valves, and temporarily attach the wire harnesses to the grader frame.

6. D700 series graders:- effective serial numbers 9008, 9010, 9027, 9030, 9050, 9058 to 9060, 9110 to 9882 and 9884 onwards:

The rear lift and slide cylinders are controlled by a double bank solenoid valve mounted on the rear mast, and the front lift cylinder is controlled by a single bank solenoid valve mounted on the grader frame.

7. Hydraulic oil is transmitted from the primary hydraulic circuit to the double bank solenoid valve; then directed to the single bank solenoid valve and the manifold valve.

8. When removing the rear mast, disconnect the two tubes at the solenoid valve and the primary hydraulic plumbing. Plug the valve fittings. Connect the hose leading to the front mast plumbing and manifold valve to the tee fitting at the pressure relief valve.

9. Remove the electrical connections to the solenoid valve, and temporarily attach the wire harnesses to the grader frame.

10. When removing the front mast, disconnect both hoses at the cylinder tube fittings. Plug the tube fittings. Remove one hose at the solenoid valve fitting. Loop the other hose, and connect to the open fitting on the solenoid valve.

11. There is no need to remove the electrical connections to the solenoid valve.

12. **WARNING:**

It is essential that reliable, heavy-duty lifting tackle is available when removing the rear mounted wing masts and blade.

Attach the lifting tackle to the wing blade (91, 93, 115 or 116, Fig. 21). Remove the two hexagon head bolts (95, Fig. 21), nuts (97, Fig. 21) and lockwashers (96, Fig. 21) retaining the knuckles (77, Fig. 21) to the wing blade.

Remove and discard the cotter pin (94, Fig. 21) retaining the pin (86, Fig. 21), and remove the pin. Disconnect the shackle (90, Fig. 21) and remove the cable (8, Fig. 21). Hoist the blade away from the grader. Remove the lifting tackle.

**NOTE:**

For machines equipped with the optional trip wing installation, remove and discard the cotter pin (119, Fig. 21) retaining the pivot plate pin (114, Fig. 21), and remove the pin. Remove and discard the cotter pin (118, Fig. 21) retaining the hexagon head bolt (110, Fig. 21). Remove the bolt and hinge plate (112, Fig. 21).

13. Attach the lifting tackle to the front mast (12, Fig. 21). Remove the hexagon head bolts (56 and 61, Fig. 21), nuts (60 and 64, Fig. 21) and lockwashers (59 and 63, Fig. 21) retaining the lower front mast brace (19, Fig. 21). Remove the hexagon head bolts (56, Fig. 21), nuts (60, Fig. 21) and lockwashers (59, Fig. 21) retaining the front mast brace (21, Fig. 21). Remove the braces.

14. Remove the four hexagon head bolts (61, Fig. 21), nuts (64, Fig. 21) and lockwashers (63, Fig. 21) retaining the front mast support to the grader frame. Carefully hoist the front mast away from the grader. Remove the lifting tackle.

15. Remove the kliprings (82, Fig. 21) securing the two attachment pins (81, Fig. 21) connection the knuckles (77, Fig. 21) to the rear mast slide (10, Fig. 21). Remove both the upper and lower stand-off arms.

16. Attach the lifting tackle to the rear mast (9, Fig. 21). Remove the hexagon head bolts (56, Fig. 21), nuts (60, Fig. 21) and lockwashers (59, Fig. 21) retaining the forward rear mast brace (20, Fig. 21). Remove the hexagon head bolts (57 and 66, Fig. 21), nuts (60 and 69, Fig. 21) and lockwashers (59 and 68, Fig. 21) retaining the rear mast brace (11, Fig. 21). Remove the braces.

17. Remove the four hexagon head bolts (67, Fig. 21), nuts (69, Fig. 21) and lockwashers (68, Fig. 21) retaining the rear mast support to the grader frame. Carefully hoist the rear mast away from the grader. Remove the lifting tackle.

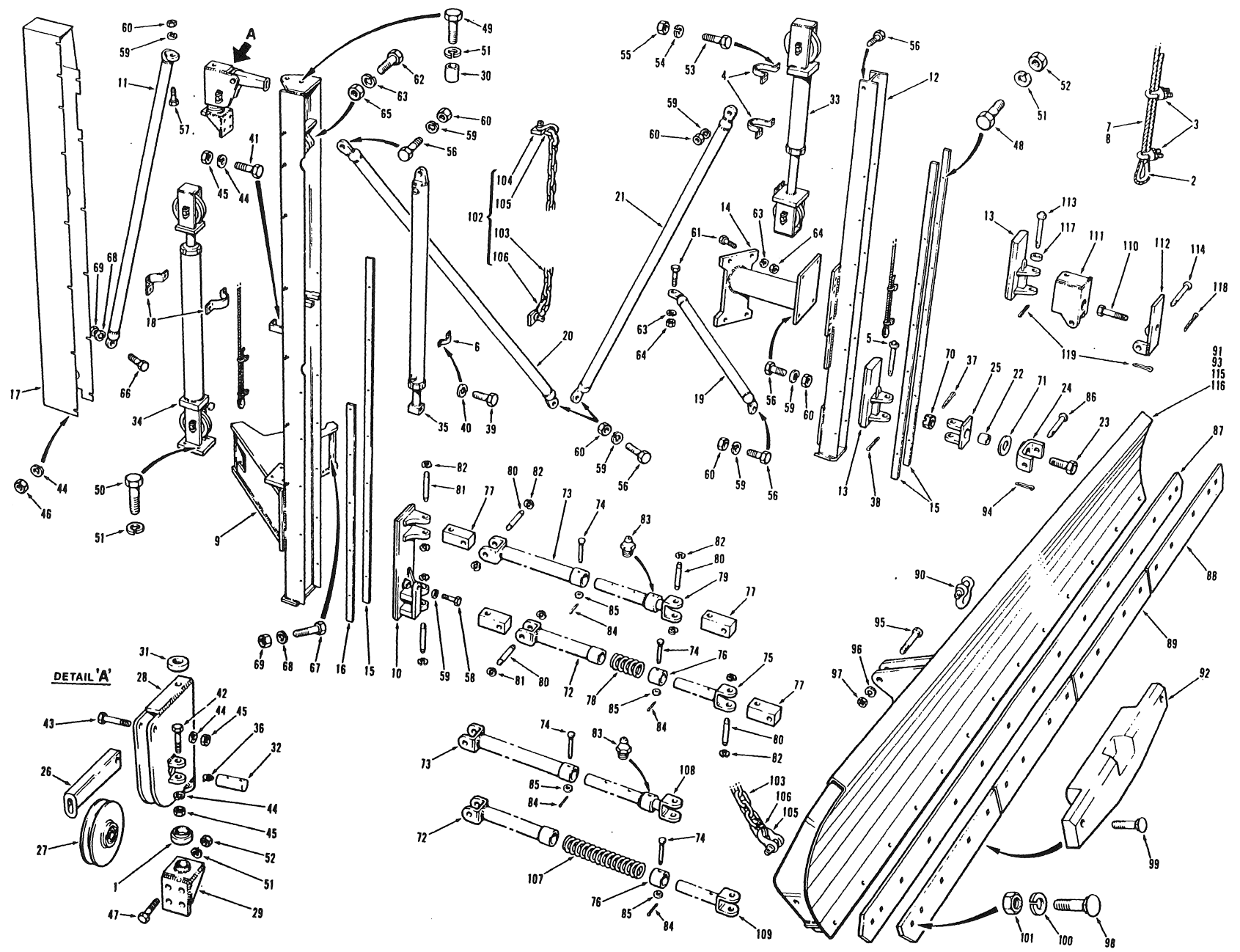

ATTACHMENTS

Figure 21

REF. NO.	DESCRIPTION	REF. NO.	DESCRIPTION	REF. NO.	DESCRIPTION
	FRONT & REAR MAST INSTALLATION	44	LOCKWASHER		WING INSTALLATION - STANDARD
1	THRUST BEARING	45	NUT	86	PIN
2	THIMBLE	46	NUT	87	WING EDGE
3	CABLE CLAMP	47	1 1/2" LG. HEX. HD. BOLT	88	WING EDGE - OUTER - CARBIDE TIPPED
4	CLAMP	48	1 3/4" LG. HEX. HD. BOLT	89	WING EDGE - INNER - CARBIDE TIPPED
5	PIN	49	2 1/4" LG. HEX. HD. BOLT	90	SHACKLE
6	CLAMP	50	1 3/4" LG. HEX. HD. BOLT	91	WING - DRILLED FOR STANDARD EDGE
7	CABLE 25' LG. - FRONT MAST	51	LOCKWASHER	92	WING SHOE
8	CABLE 52' LG. - REAR MAST	52	NUT	93	WING - DRILLED FOR CARBIDE EDGES
9	REAR MAST	53	1 3/4" LG. HEX. HD. BOLT	94	COTTER PIN
10	SLIDE ASSY. - REAR MAST	54	LOCKWASHER	95	5 1/2" LG. HEX. HD. BOLT
11	REAR MAST BRACE	55	NUT	96	LOCKWASHER
12	FRONT MAST	56	2 1/2" LG. HEX. HD. BOLT	97	NUT
13	SLIDE ASSY. - FRONT MAST	57	3" LG. HEX. HD. BOLT	98	2" LG. PLOW BOLT
14	MAST MOUNTING BRACKET	58	4" LG. HEX. HD. BOLT	99	3 1/2" LG. PLOW BOLT
15	SLIDE GUIDE - LONG	59	LOCKWASHER	100	LOCKWASHER
16	SLIDE GUIDE - SHORT	60	NUT	101	NUT
17	ICE SHIELD	61	1/2" LG. HEX. HD. BOLT	102	WING SAFETY CHAIN ASSY.
18	CLAMP	62	4" LG. HEX. HD. BOLT	103	CHAIN - 33" LG.
19	FRONT MAST BRACE - LOWER	63	LOCKWASHER	104	LUG
20	REAR MAST BRACE - FWD.	64	NUT	105	SHACKLE
21	FRONT MAST BRACE	65	NUT	106	SPLIT LINK
22	SPACER	66	4" LG. HEX. HD. BOLT		
23	SWIVEL PIN	67	4 1/2" LG. HEX. HD. BOLT		
24	MOUNTING SWIVEL	68	LOCKWASHER		
25	HINGE	69	NUT		
26	CABLE GUIDE	70	JAM NUT		
27	SHEAVE ASSY.	71	FLATWASHER		
28	SWIVEL HOUSING		STAND-OFF ARMS INSTALLATION-STANDARD		
29	BRACKET				
30	SPACER BUSHING	72	OUTER SLEEVE - LOWER ARM	107	SPRING
31	SPACER COLLAR	73	OUTER SLEEVE - UPPER ARM	108	INNER SLEEVE - UPPER ARM
32	SHEAVE PIN	74	SHEAR PIN	109	INNER SLEEVE - LOWER ARM
33	LIFT CYLINDER - FRONT MAST	75	INNER SLEEVE - LOWER ARM	110	WING BOLT
34	LIFT CYLINDER - REAR MAST	76	COLLAR	111	SWIVEL ASSY.
35	SLIDE CYLINDER	77	KNUCKLE	112	HINGE PLATE
36	45° GREASE FITTING	78	SPRING	113	SWIVEL PIN
37	COTTER PIN	79	INNER SLEEVE - UPPER ARM	114	PIVOT PLATE PIN
38	COTTER PIN	80	1" DIA. X 5" LG. PIN	115	TRIP WING - DRILLED FOR STD. EDGE
39	1" LG. HEX. HD. BOLT	81	1" DIA. X 6" LG. PIN	116	TRIP WING - DRILLED FOR CARBIDE EDGES
40	LOCKWASHER	82	KLIPRING FASTENER	117	SPACER WASHER
41	1 1/2" LG. HEX. HD. BOLT	83	STRAIGHT GREASE FITTING	118	COTTER PIN
42	2" LG. HEX. HD. BOLT	84	COTTER PIN	119	COTTER PIN
43	2 1/2" LG. HEX. HD. BOLT	85	FLATWASHER		

ATTACHMENTS

KEY TO FIG. 21

## ATTACHMENTS

18. To disassemble the front mast and components, proceed as follows:

- a. Remove the four cable clamps (3, Fig. 21) securing the cable ends (7, Fig. 21). Release the two thimbles (2, Fig. 21), and remove the cable.
- b. Attach lifting tackle to the lift cylinder (33, Fig. 21). Remove the cylinder plumbing. Remove the four hexagon head bolts (53, Fig. 21), nuts (55, Fig. 21) and lockwashers (54, Fig. 21) retaining the two clamps (4, Fig. 21). Remove the clamps and cylinder.
- c. Remove the hexagon head bolts (3 and 19, Fig. 22), nuts (1 and 17, Fig. 22) and lockwashers (2 and 18, Fig. 22) retaining the sheave pins (7 and 15, Fig. 22). Remove the sheave pins and sheaves (5, 6 and 16, Fig. 22). Remove the two hexagon head capscrews (11, Fig. 22), lockwashers (12, Fig. 22) and flatwashers (13, Fig. 22), and remove the ice scraper (10, Fig. 22).

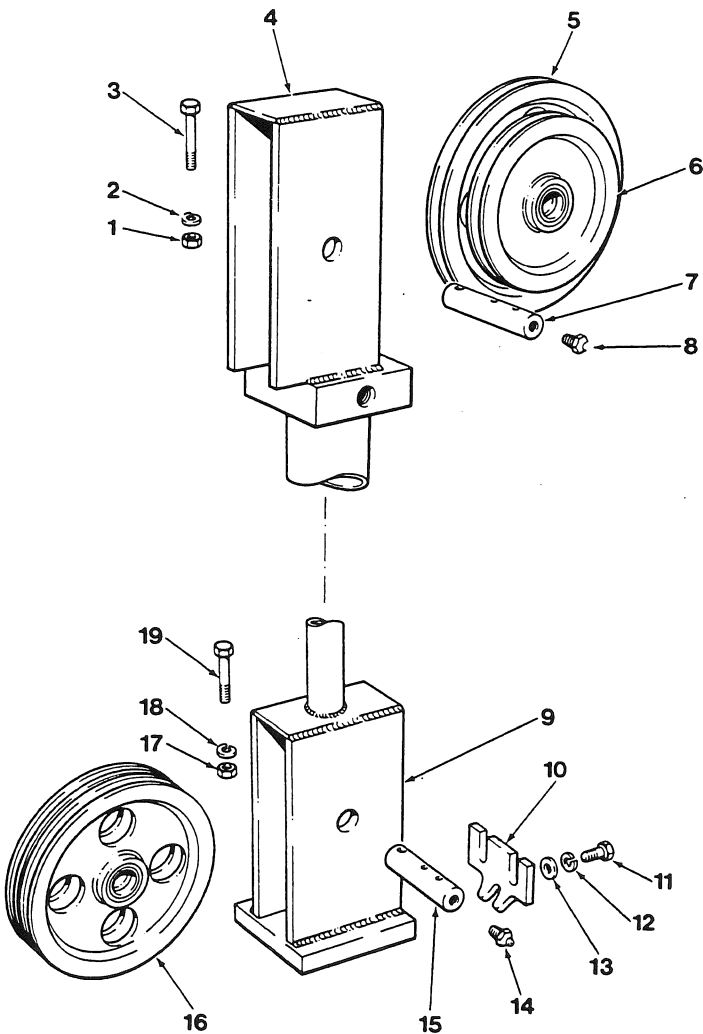

Figure 22

- d. Remove the seven hexagon head bolts (48, Fig. 21), nuts (52, Fig. 21) and lockwashers (51, Fig. 21) retaining each slide guide (15, Fig. 21), and remove the guides.
- e. Remove and discard the cotter pin (38, Fig. 21) retaining the pin (5, Fig. 21), and remove the hinge assembly from the slide (13, Fig. 21). Remove the slide.
- f. Remove and discard the cotter pin (37, Fig. 21) retaining the hexagon head bolt (23, Fig. 21). Remove the bolt and jam nut (70, Fig. 21), and separate the hinge (25, Fig. 21), spacer (22, Fig. 21), flatwasher (71, Fig. 21) and mounting swivel (24, Fig. 21).

**NOTE:**

For machines equipped with the optional trip wing installation, remove and discard the cotter pin (119, Fig. 21) retaining the swivel pin (113, Fig. 21). Remove the swivel pin, spacer washer (117, Fig. 21) and swivel assembly (111, Fig. 21). Remove the slide (13, Fig. 21).

19. To disassemble the rear mast components, proceed as follows:

- a. Remove the eight nuts (46, Fig. 21) and lockwashers (44, Fig. 21) retaining the ice shield (17, Fig. 21), and remove the ice shield.
- b. Remove the cable clamps (3, Fig. 21) securing the cable ends (8, Fig. 21). Release the two thimbles (2, Fig. 21), and remove the cable.

REF. NO.

DESCRIPTION

1	NUT
2	LOCKWASHER
3	2 1/4" LG. HEX. HD. BOLT
4	UPPER SHEAVE HOUSING
5	SHEAVE - 9 1/2" O.D.
6	SHEAVE - 7" O.D.
7	SHEAVE PIN
8	STRAIGHT GREASE FITTING
9	LOWER SHEAVE HOUSING
10	ICE SCRAPER
11	1" LG. HEX. HD. CAPSCREW
12	LOCKWASHER
13	FLATWASHER
14	STRAIGHT GREASE FITTING
15	SHEAVE PIN
16	SHEAVE - 8 1/2" O.D.
17	NUT
18	LOCKWASHER
19	2 1/4" LG. HEX. HD. BOLT

KEY TO FIG. 22



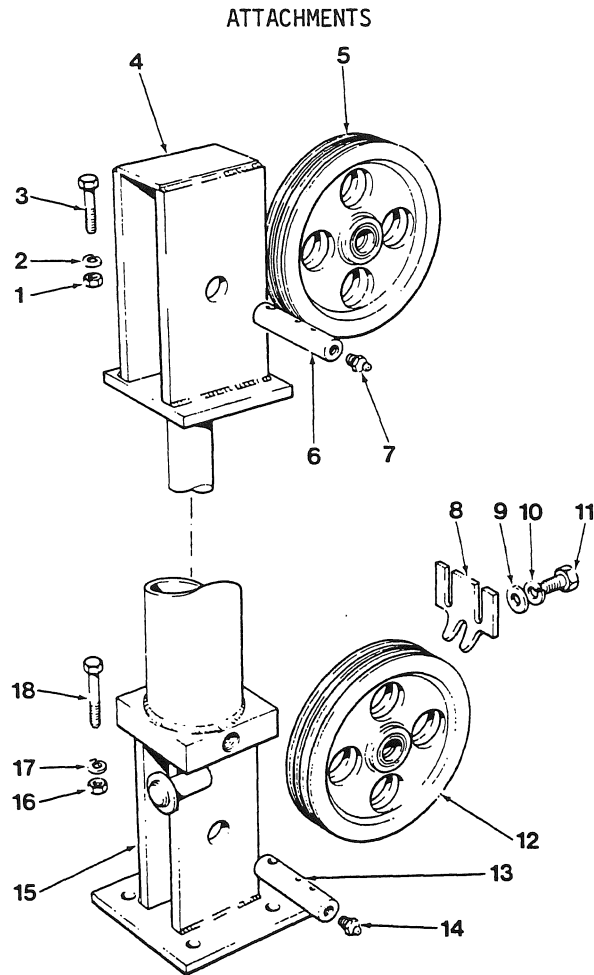

Figure 23

REF. NO.	DESCRIPTION	REF. NO.	DESCRIPTION
1	NUT	10	LOCKWASHER
2	LOCKWASHER	11	1" LG. HEX. HD. CAPSCREW
3	2 1/4" LG. HEX. HD. BOLT	12	SHEAVE - 8 1/2" O.D.
4	UPPER SHEAVE HOUSING	13	SHEAVE PIN
5	SHEAVE - 8 1/2" O.D.	14	STRAIGHT GREASE FITTING
6	SHEAVE PIN	15	LOWER SHEAVE HOUSING
7	STRAIGHT GREASE FITTING	16	NUT
8	ICE SCRAPER	17	LOCKWASHER
9	FLATWASHER	18	2 1/4" LG. HEX. HD. BOLT

KEY TO FIG. 23

- c. Remove the two hexagon head bolts (41, Fig. 21), nuts (45, Fig. 21) and lockwashers (44, Fig. 21) retaining the two clamps (18, Fig. 21).
- d. Attach lifting tackle to the lift cylinder (34, Fig. 21). Remove the cylinder plumbing. Remove the four hexagon head bolts (50, Fig. 21) and lockwashers (51, Fig. 21) retaining the cylinder base plate. Remove the cylinder.
- e. Remove the hexagon head bolts (3 and 18, Fig. 23), nuts (1 and 16, Fig. 23) and lockwashers (2 and 17, Fig. 23) retaining the sheave pins (6 and 13, Fig. 23). Remove the sheave pins and sheaves (5 and 12, Fig. 23). Re-

- move the two hexagon head capscrews (11, Fig. 23), lockwashers (10, Fig. 23) and flatwashers (9, Fig. 23), and remove the ice scraper (8, Fig. 23).
- f. Remove the hexagon head capscrew (58, Fig. 21) and lockwasher (59, Fig. 21) retaining the slide cylinder piston rod to the slide. Remove the cylinder plumbing. Remove the two hexagon head capscrews (39, Fig. 21) and lockwashers (40, Fig. 21) retaining the clamp (6, Fig. 21). Remove the hexagon head bolt (62, Fig. 21), nut (65, Fig. 21) and lockwasher (63, Fig. 21) retaining the slide cylinder (35, Fig. 21) to the rear mast lugs. Remove the cylinder.

## ATTACHMENTS

- g. Remove the twelve hexagon head bolts (48, Fig. 21), nuts (52, Fig. 21) and lockwashers (51, Fig. 21) retaining the long and short slide guides (15 and 16, Fig. 21), and remove the guides. Remove the slide.
  - h. Remove the hexagon head capscrew (49, Fig. 21), lockwasher (51, Fig. 21) and spacer washer (30, Fig. 21). Remove the four hexagon head bolts (47, Fig. 21), nuts (52, Fig. 21) and lockwashers (51, Fig. 21) retaining the swivel housing bracket (29, Fig. 21). Remove the bracket, together with the swivel housing assembly, spacer collar (31, Fig. 21) and thrust bearing (1, Fig. 21). Inspect the thrust bearing for serviceability. Replace a faulty bearing.
  - i. Remove the hexagon head bolt (43, Fig. 21), nut (45, Fig. 21) and lockwasher (44, Fig. 21) securing the cable guide (26, Fig. 21), and remove the guide.
  - j. Remove the hexagon head bolt (42, Fig. 21), nut (45, Fig. 21) and lockwasher (44, Fig. 21) retaining the sheave pin (32, Fig. 21). Remove the sheave pin and sheave (27, Fig. 21) from the swivel housing (28, Fig. 21).
  - k. Remove the four hexagon head bolts (56, Fig. 21), nuts (60, Fig. 21) and lockwashers (59, Fig. 21) retaining the mast mounting bracket (14, Fig. 21).
  - l. D700 series graders:- effective serial numbers 9008, 9010, 9027, 9030, 9050, 9058 to 9060, 9110 to 9882 and 9884 onwards:  
Remove the hardware retaining the solenoid valve ice shield to the mast, and remove the ice shield.
  - m. For machines equipped with the optional wing safety chain assembly (102, Fig. 21), remove the two shackles (105, Fig. 21) at the lugs (104, Fig. 21), and remove the chain (103, Fig. 21). The chain can also be removed at the two split links (106, Fig. 21).
20. To disassemble the upper and lower stand-off arms, proceed as follows:
- a. Remove the kliprings (82, Fig. 21) securing the attachment pins (80, Fig. 21) connecting the knuckles (77, Fig. 21) to the inner sleeves (79 and 75, or 108 and 109, Fig. 21) and the outer sleeves (73 and 72, Fig. 21).
  - b. Remove and discard the cotter pins (84, Fig. 21) retaining the shear pins (74, Fig. 21). Remove the shear pins and flatwashers (85, Fig. 21), and separate the inner and outer sleeves.
  - c. Remove the collar (76, Fig. 21) and spring (78 or 107, Fig. 21).
21. Assembly and Installation (Figs. 21, 22 and 23). To assemble the upper and lower stand-off arms, proceed as follows:
- a. Install the collar (76, Fig. 21) and spring (78 or 107, Fig. 21) onto the lower stand-off arm inner sleeves (75 or 109, Fig. 21). Retain the collar with the shear pin (74, Fig. 21), flatwasher (85, Fig. 21) and a new cotter pin (84, Fig. 21).
  - b. Insert the inner sleeves into the outer sleeves (73 and 72, Fig. 21). Retain the inner and outer sleeves of the upper stand-off arms with the shear pin (74, Fig. 21), flatwasher (85, Fig. 21) and a new cotter pin (84, Fig. 21).
  - c. Install the knuckles (77, Fig. 21), and retain with the attachment pins (80, Fig. 21). Secure the attachment pins with the kliprings (82, Fig. 21).
22. To assemble the rear mast and components, proceed as follows:
- a. Install the sheave (27, Fig. 21) into the swivel housing (28, Fig. 21), and retain with the sheave pin (32, Fig. 21). Retain the sheave pin with the hexagon head bolt (42, Fig. 21), nut (45, Fig. 21) and lockwasher (44, Fig. 21).
  - b. Install the cable guide (26, Fig. 21), and secure with the hexagon head bolt (43, Fig. 21), nut (45, Fig. 21) and lockwasher (44, Fig. 21).
  - c. Install the swivel housing bracket (29, Fig. 21), and retain with the four hexagon head bolts (47, Fig. 21), nuts (52, Fig. 21) and lockwashers (51, Fig. 21).
  - d. Install the swivel housing assembly, together with the thrust bearing (1, Fig. 21) and spacer collar (31, Fig. 21). Retain the swivel housing with the hexagon head capscrew (49, Fig. 21), lockwasher (51, Fig. 21) and spacer washer (30, Fig. 21).
  - e. Install the slide (10, Fig. 21). Install the long and short slide guides (15 and 16, Fig. 21), and retain with the twelve hexagon head bolts (48, Fig. 21), nuts (52, Fig. 21) and lockwashers (51, Fig. 21).
  - f. Place the slide cylinder (35, Fig. 21) into position on the rear mast, and retain to the lugs with the hexagon

ATTACHMENTS

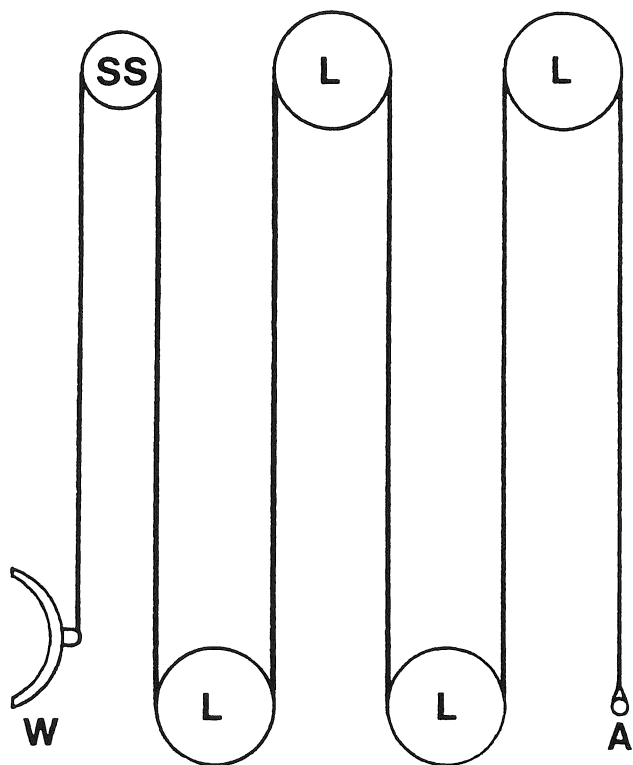

- A ANCHOR
- SS SWIVEL SHEAVE
- L LARGE SHEAVE
- W WING BLADE

Figure 24

- head bolt (62, Fig. 21), nut (65, Fig. 21) and lockwasher (63, Fig. 21). Install the clamp (6, Fig. 21), and retain with the two hexagon head capscrews (39, Fig. 21) and lockwashers (40, Fig. 21). Retain the slide cylinder piston rod to the slide with the hexagon head capscrew (58, Fig. 21) and lockwasher (59, Fig. 21). Install the cylinder plumbing.
- g. Install the sheaves (5 and 12, Fig. 23) into the sheave housings, and retain with the sheave pins (6 and 13, Fig. 23). Retain the pins with the hexagon head bolts (3 and 18, Fig. 23), nuts (1 and 16, Fig. 23) and lockwashers (2 and 17, Fig. 23). Install the ice scraper (8, Fig. 23), and retain with the two hexagon head capscrews (11, Fig. 23), lockwashers (10, Fig. 23) and flatwashers (9, Fig. 23).
  - h. Install the lift cylinder (34, Fig. 21), and retain the base plate with four hexagon head bolts (50, Fig. 21), and lockwashers (51, Fig. 21). Install the cylinder plumbing.

- i. Install the two clamps (18, Fig. 21), and retain with the two hexagon head bolts (41, Fig. 21), nuts (45, Fig. 21) and lockwashers (44, Fig. 21).
- j. Install a thimble (2, Fig. 21) at one end of the cable (8, Fig. 21), and install on the anchor pin. Install the cable clamps (3, Fig. 21) (nuts on the opposite side to the cable dead end), and torque-tighten the nuts to 65 ft/lb (8,9 kg/m).
- k. Thread the cable around the sheaves as shown in Fig. 24. Install a thimble on the other end of the cable. Install the cable clamps (nuts on the opposite side to the cable dead end), and torque-tighten the nuts to 65 ft/lb (8,9 kg/m).
- l. Install the ice shield (17, Fig. 21), and retain to the mast with the eight nuts (46, Fig. 21) and lockwashers (44, Fig. 21).
- m. Place the mast mounting bracket (14, Fig. 21) into position, and retain with the four hexagon head bolts (56, Fig. 21), nuts (60, Fig. 21) and lockwashers (59, Fig. 21).
- n. D700 series graders:- effective serial numbers 9008, 9010, 9027, 9030, 9050, 9058 to 9060, 9110 to 9882 and 9884 onwards:  
Install the solenoid valve ice shield to the mast, and retain with the hardware.
- o. For machines equipped with the optional wing safety chain assembly (102, Fig. 21), install the chain (103, Fig. 21) and secure either at the two split links (106, Fig. 21), or the two shackles (105, Fig. 21) at the lugs (104, Fig. 21).

23. To assemble the front mast and components, proceed as follows:

- a. Install the mounting swivel (24, Fig. 21), flatwasher (71, Fig. 21), spacer (22, Fig. 21) and hinge (25, Fig. 21) onto the hexagon head bolt (23, Fig. 21). Retain the bolt with the jam nut (70, Fig. 21), and secure with a new cotter pin (37, Fig. 21).

NOTE:

For machines equipped with the optional trip wing installation, install the swivel assembly (111, Fig. 21) to the slide (13, Fig. 21), and retain with the swivel pin (113, Fig. 21) and spacer washer (117, Fig. 21). Secure the swivel pin with a new cotter pin (119, Fig. 21).

ATTACHMENTS

- b. Install the mounting swivel assembly onto the slide (13, Fig. 21), and retain with the pin (5, Fig. 21). Secure the pin with a new cotter pin (38, Fig. 21).
- c. Place the slide assembly into position in the mast channel. Install the two slide guides (15, Fig. 21), and retain with the fourteen hexagon head bolts (48, Fig. 21), nuts (52, Fig. 21) and lockwashers (51, Fig. 21).
- d. Install the sheaves (5, 6 and 16, Fig. 22) and sheave pins (7 and 15, Fig. 22). Retain the sheave pins with the hexagon head bolts (3 and 19, Fig. 22), nuts (1 and 17, Fig. 22) and lockwashers (2 and 18, Fig. 22). Install the ice scraper (10, Fig. 22), and retain with the two hexagon head capscrews (11, Fig. 22), lockwashers (12, Fig. 22) and flatwashers (13, Fig. 22).
- e. Attach suitable lifting tackle to the lift cylinder (33, Fig. 21) and place into position on the mast. Install the two clamps (4, Fig. 21), and retain with the four hexagon head bolts (53, Fig. 21), nuts (55, Fig. 21) and lockwashers (54, Fig. 21). Remove the lifting tackle. Install the cylinder plumbing.

- f. Install a thimble (2, Fig. 21) at one end of the cable (7, Fig. 21), and install on the anchor pin. Install the cable clamps (3, Fig. 21) (nuts on the opposite side to the cable dead end), and torque-tighten the nuts to 65 ft/lb (8,9 kg/m).
- g. Thread the cable around the sheaves as shown in Fig. 25. Install a thimble at the other end of the cable, and install on the slide U-bolt. Install the cable clamps (nuts on the opposite side to the cable dead end), and torque-tighten the nuts to 65 ft/lb (8,9 kg/m).

24.

WARNING:

It is essential that reliable, heavy-duty lifting tackle is available when installing the rear mounted wing masts and blade.

Attach the lifting tackle to the rear mast (9, Fig. 21), and place into position at the grader frame. Install the four hexagon head bolts (67, Fig. 21), nuts (69, Fig. 21) and lockwashers (68, Fig. 21) retaining the mast support.

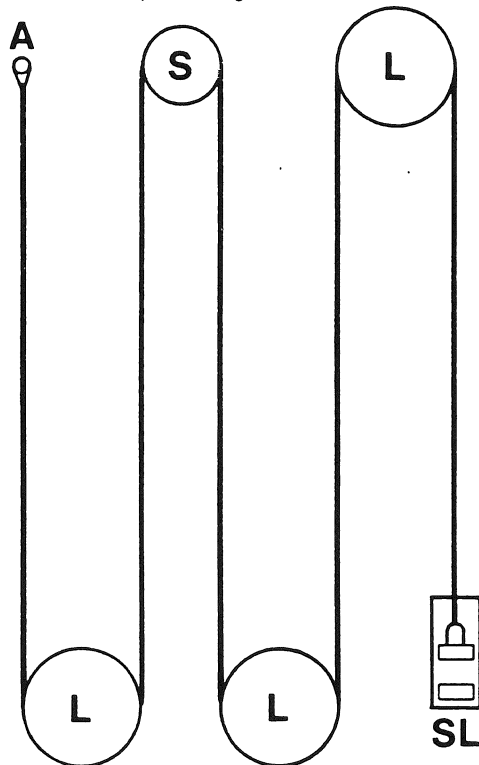

- A ANCHOR
- S SMALL SHEAVE
- L LARGE SHEAVE
- SL SLIDE

Figure 25

- 25. Install the forward rear mast brace (20, Fig. 21), and retain with the hexagon head bolts (56, Fig. 21), nuts (60, Fig. 21) and lockwashers (59, Fig. 21). Install the rear mast brace (11, Fig. 21), and retain with the hexagon head bolts (57 and 66, Fig. 21), nuts (60 and 69, Fig. 21) and lockwashers (59 and 68, Fig. 21).
- 26. Place the upper and lower stand-off arms into position at the rear mast slide (10, Fig. 21). Connect the knuckles (77, Fig. 21) to the slide, and retain with the two attachment pins (81, Fig. 21). Secure the pins with the kliprings (82, Fig. 21). Remove the lifting tackle.
- 27. Attach the lifting tackle to the front mast (12, Fig. 21), and place into position at the grader frame. Install the four hexagon head bolts (61, Fig. 21), nuts (64, Fig. 21) and lockwashers (63, Fig. 21).
- 28. Install the front mast brace (21, Fig. 21), and retain with the hexagon head bolts (56, Fig. 21), nuts (60, Fig. 21) and lockwashers (59, Fig. 21). Install the lower front mast brace (19, Fig. 21), and retain with the hexagon head bolts (56 and 61 Fig. 21), nuts (60 and 64, Fig. 21) and lockwashers (59 and 63, Fig. 21). Remove the lifting tackle.

## ATTACHMENTS

29. Attach the lifting tackle to the wing blade (91, 93, 115 or 116, Fig. 21). Place into position at the upper and lower stand-off arms, and retain with the hexagon head bolts (95, Fig. 21), nuts (97, Fig. 21) and lockwashers (96, Fig. 21). Install the pin (86, Fig. 21) to connect the wing blade and front mast swivel. Secure the pin with a new cotter pin (94, Fig. 21). Install the cable (8, Fig. 21), and retain with the shackle (90, Fig. 21).

### NOTE:

For machines equipped with the optional trip wing installation, install the hinge plate (112, Fig. 21), and retain with the hexagon head bolt (110, Fig. 21). Secure the bolt with a new cotter pin (118, Fig. 21). Connect the swivel (111, Fig. 21) to the hinge plate with the pivot plate pin (114, Fig. 21). Secure the pin with a new cotter pin (119, Fig. 21).

Remove the lifting tackle.

30. D700 series graders:- effective serial numbers up to 9007, 9011 to 9026, 9029, 9031 to 9049, 9051 to 9057 and 9098 to 9107:  
After installing the front mast, disconnect the looped hose. Install the second hose to the tube on the frame. Re-connect both hoses to the cylinder tube fittings.
31. After installing the rear mast, disconnect the looped hose. Install the second hose at the tee fitting. Re-connect both hoses at the solenoid valve.
32. Install the electrical connections to the solenoid valve.
33. D700 series graders:- effective serial numbers 9008, 9010, 9027, 9030, 9050, 9058 to 9060, 9110 to 9882 and 9884 onwards:  
After installing the front mast, disconnect the looped hose. Install the second hose at the solenoid valve. Re-connect both hoses to the cylinder tube fittings.

34. After installing the rear mast, disconnect the hose leading to the front mast plumbing and manifold valve at the tee fitting. Re-connect the two tubes to the solenoid valve and the primary hydraulic plumbing.
35. Install the electrical connections to the solenoid valve.
36. Adjustments (Figs. 21 and 26). The amount of wing blade angle and pitch can be varied by adjusting the inner sleeves within the outer sleeves of the stand-off arms. Remove the cotter pins and shear pins, adjust the inner sleeves, and install the shear pins in the nearest alternative hole (1, Fig. 26). Secure with the cotter pins. Wing blade front end height adjustment is achieved by selecting an alternative hole in the blade strengthening plate (2, Fig. 26).
37. Worn edges (87, 88 or 89, Fig. 21) can be replaced by removing the required quantity of carriage bolts (98, Fig. 21), nuts (101, Fig. 21) and lockwashers (100, Fig. 21), then removing the edges.
38. Install new edges, and retain with the carriage bolts, nuts and lockwashers.
39. Worn wing shoes (92, Fig. 21) can be replaced by removing the required quantity of carriage bolts (99, Fig. 21), nuts (101, Fig. 21) and lockwashers (100, Fig. 21), then removing the shoes.
40. Install new shoes, and retain with the carriage bolts, nuts and lockwashers.

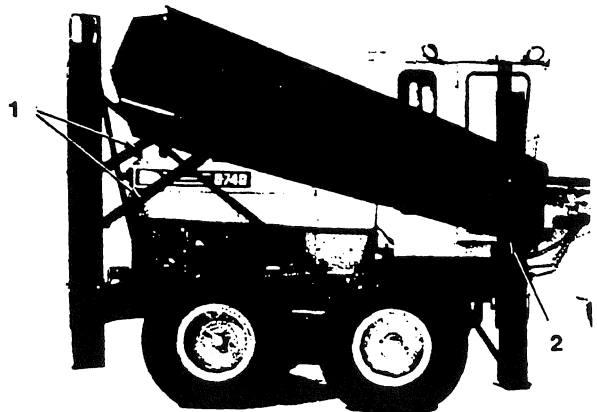

Figure 26

