

SECTION 15

HAND BRAKE

Hand Brake Caliper Assembly Mounted on the Transmission Housing

Models: 710 through 740A S/N 16224, 16245 and up

Models: 750 through 780A up to S/N 21006

U.S. S/N 2012-2 to 2658-2

Hand Brake Caliper Assembly Mounted on the Frame

Models: 750 through 780A S/N 21007 and up

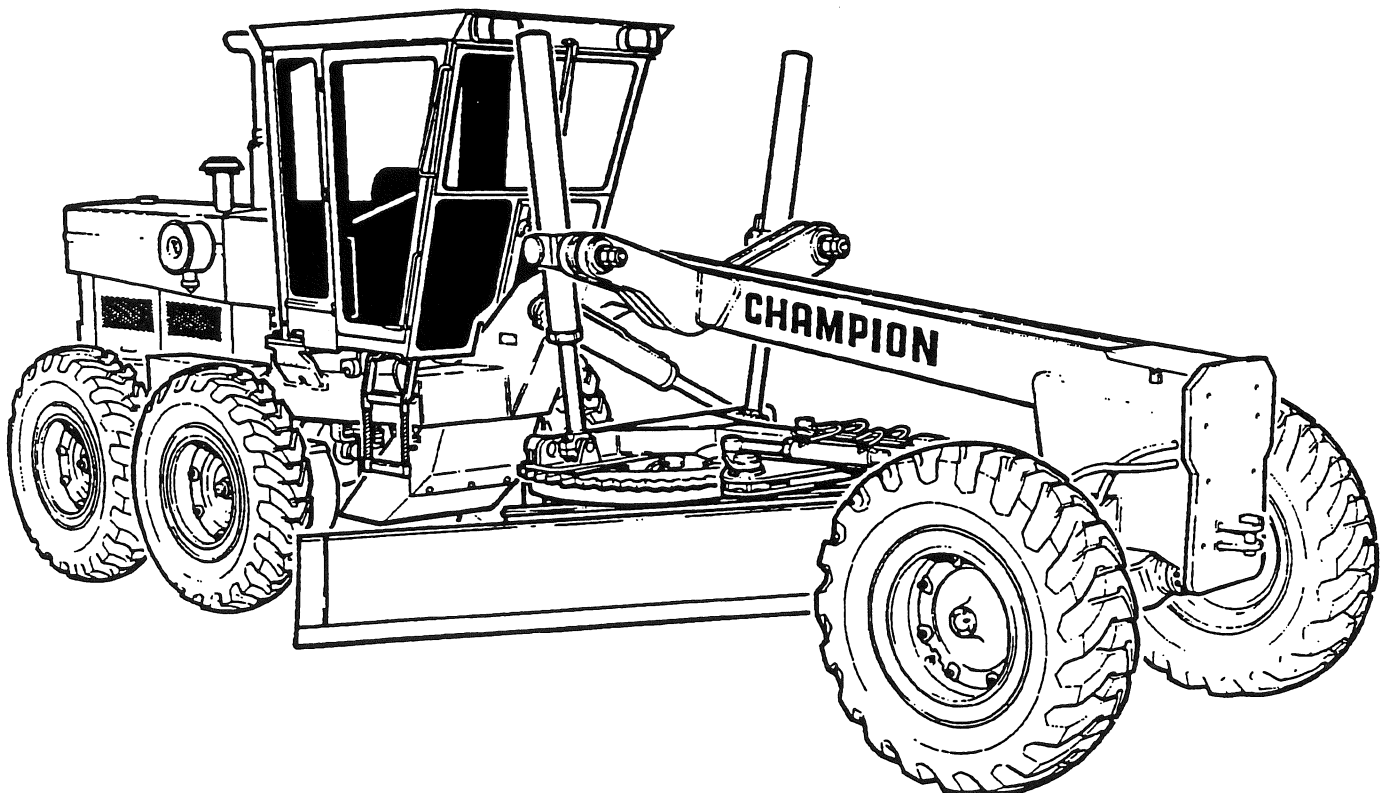

700 SERIES SHOP MANUAL

HAND BRAKE

Hand Brake Caliper Assembly Mounted on the Transmission Housing

Models: 710 through 740A S/N 16224, 16245 and up

Models: 750 through 780A up to S/N 21006

U.S. S/N 2012-2 to 2658-2

Hand Brake Caliper Assembly Mounted on the Frame

Models: 750 through 780A S/N 21007 and up

TABLE OF CONTENTS

PAGE

General	4
Service Position Precaution	4
Description	4
Cleaning and Inspection	4
Cleaning	4
Inspection	5
Torque Guide	5
Hand Brake - Removal and Disassembly	6
- Assembly and Installation	13
- Adjustment and Testing	17
Hand Brake Caliper Assembly Mounted on the Frame (Models 750 through 780A)	20
Description (Models 750 through 780A)	21
Disassembly (Models 750 through 780A)	21
Cleaning and Inspection (Models 750 through 780A)	22
Assembly (Models 750 through 780A)	22
Installing and Adjusting Hand Brake Cable (Models 750 through 780A)	23
Hand Brake Function Test (Models 750 through 780A)	23
Burnishing Friction Pads (Models 750 through 780A)	24
Engine Stall Test (Models 750 through 780A)	24

700 SERIES SHOP MANUAL

HAND BRAKE

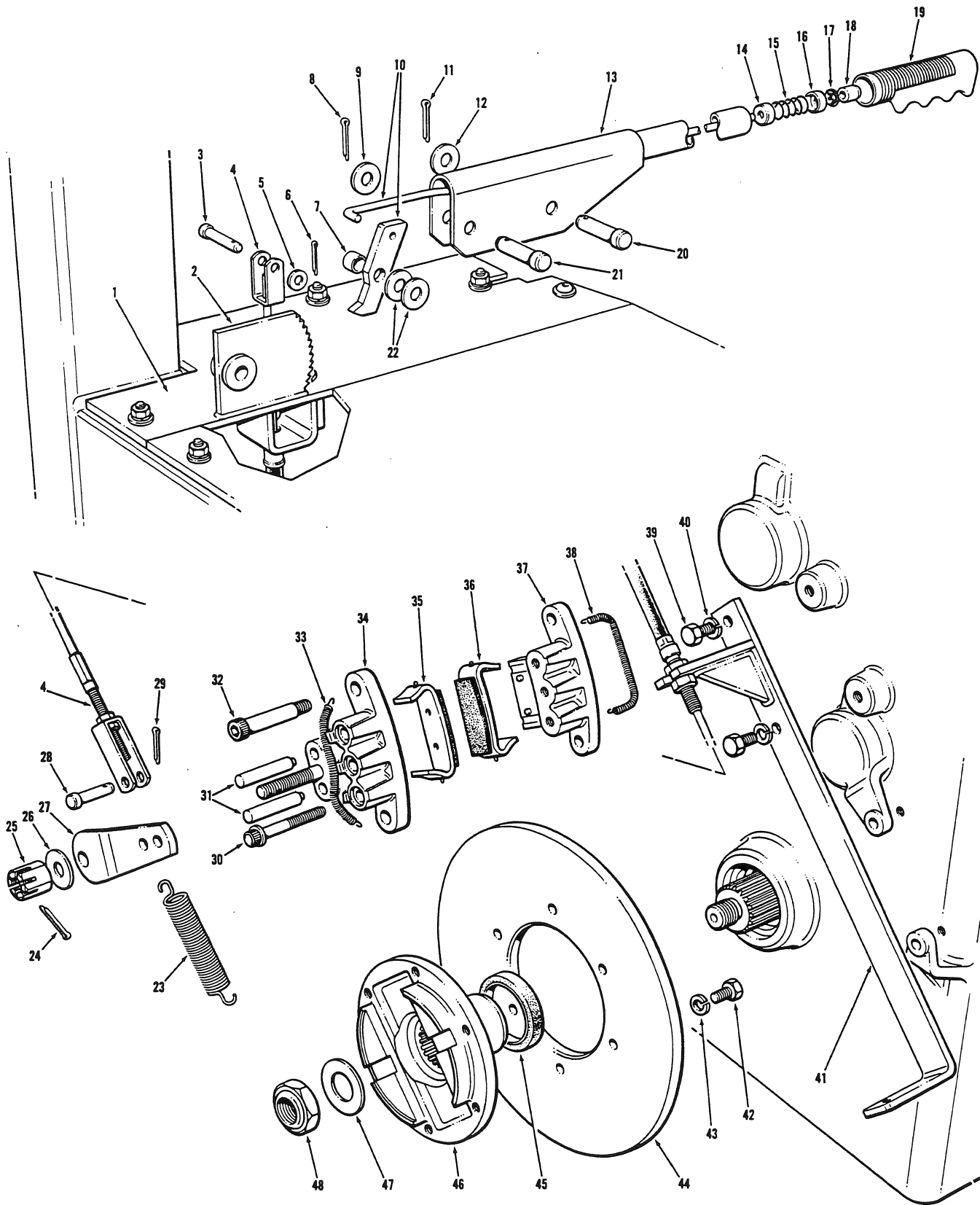

Fig. 1
Models 710 through 740A S/N 16224, 16245 and up
Models 750 through 780A up to S/N 21006
U.S. S/N 2012-2 to 2658-2

700 SERIES SHOP MANUAL

HAND BRAKE

Item	Description	Item	Description	Item	Description
1	Seat Deck Plate	17	Spring Clip Fastener	33	Spring
2	Ratchet	18	Release Button	34	Casting
3	Clevis Pin	19	Handle Grip	35	Friction Pad Holder
4	Hand Brake Cable	20	Clevis Pin	36	Friction Pad Holder
5	Washer	21	Clevis Pin	37	Casting
6	Cotter Pin	22	Washer	38	Spring
7	Spacer	23	Spring	39	Bolt
8	Cotter Pin	24	Cotter Pin	40	Lockwasher
9	Washer	25	Castle Nut	41	Cable Anchor Bracket
10	Pawl and Pawl Rod	26	Washer	42	Bolt
11	Cotter Pin	27	Operating Cam	43	Lockwasher
12	Washer	28	Clevis Pin	44	Disc
13	Handle	29	Cotter Pin	45	Oil Seal
14	Spacer Washer	30	Bolt	46	Yoke
15	Spring	31	Push Pin	47	Flatwasher
16	Spacer Washer	32	Bolt	48	Locknut

Key to Fig. 1

Models 710 through 740A S/N 16224, 16245 and up

Models 750 through 780A up to S/N 21006

U.S. S/N 2012-2 to 2658-2

700 SERIES SHOP MANUAL

HAND BRAKE

General

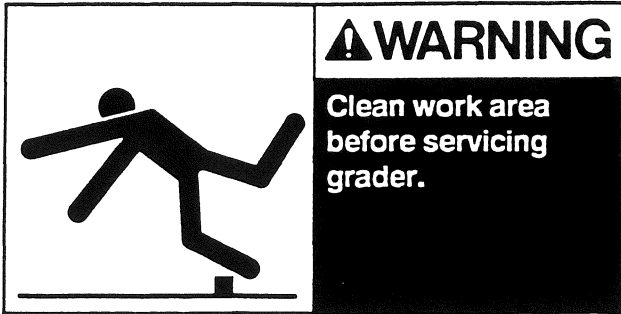

Make sure proper shop tools are available and in good working order. The brake caliper assembly should be serviced on a clean workbench. Refer to the 700 Series Parts Manual for spare parts information.

Service Position Precaution

Place the grader in the SERVICE POSITION before attempting any overhaul, maintenance or inspection procedure.

Refer to the SERVICE POSITION details on page (ii) in the front of this Shop Manual.

NOTE: Weights, measures and tolerances are in U.S., Imperial and Metric (SI) quantities. International standards specify the comma as the decimal point in all Metric measurements.

Description

The mechanically actuated, disc type hand brake is mounted on the rear of the transmission housing. Operating the handle in the cab engages and disengages the hand brake caliper assembly.

When applying the hand brake, press the handle release button to disengage the pawl. Pull the handle upward. This action pulls the cable attached to the operating cam.

Two push pins contact the operating cam and one of the friction pad holders. Moving the operating cam forces the push pins and friction pad holder inward against the disc. The second friction pad holder engages the other side of the disc.

The hand brake should be applied only when the grader is stationary and the transmission is in Neutral mode. However, you can use the hand brake in an emergency. Refer to your 700 Series Operator's Manual for emergency braking procedures.

When releasing the hand brake, press the handle release button to disengage the pawl. Lower the handle. The spring returns the cable and operating cam into their original positions. Similarly, return spring action releases the friction pad holders from the disc.

Do not drive the grader with the cable disconnected. If the grader must be moved during servicing, disconnect the return spring. The brake caliper assembly can engage when the machine is moving and excessive brake drag may result if the return spring is not disconnected.

Cleaning and Inspection

Cleaning

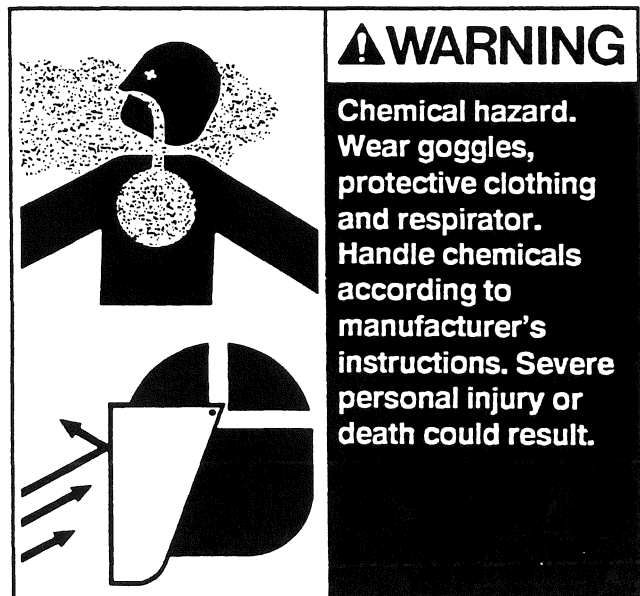

700 SERIES SHOP MANUAL HAND BRAKE

Cleaning (Continued)

Immerse small parts into a cleaning solvent. You can use a hot tank system and a mild alkali solvent. Agitate the parts to remove all foreign matter.

NOTE: Do not clean the friction pad holders.

Parts should remain in the solvent long enough to be thoroughly cleaned. In the hot tank system, heated parts help to evaporate the solvent and rinse water. Thoroughly rinse parts to remove all traces of dirt and solvent.

After rinsing, immediately dry the parts using moisture-free compressed air or lint-free rags.

Inspection

A careful and thorough inspection of all parts is extremely important. Check the brake disc surface condition. Replace the disc if it is badly warped or pitted. The disc should run true to within 0.010 in. (0,25 mm). Check friction pad wear. If the pads are worn to less than 1/32 in. (0,79 mm), replace them. Always replace both pads at the same time.

Torque Guide

Fig. No.	Application	Torque Value		
		lbf.ft	N.m	kgf.m
26	Bolts retaining castings	80 - 90	108 - 122	11 - 12
30	Bolts retaining disc to yoke	80	108	11
33	Locknut retaining disc and yoke assembly	120 - 150	163 - 203	17 - 21
34	Bolts retaining lower drive shaft to yoke	80	108	11
35	Shoulder bolts for caliper assembly	32	43	4,5

700 SERIES SHOP MANUAL

HAND BRAKE

Hand Brake - Removal and Disassembly

Fig. 2

Park the grader on level ground. Place the transmission mode lever in Neutral. Centralize the circle, drawbar and moldboard assembly using the circle shift and blade lift cylinders. Lower the moldboard onto wooden blocks.

Fig. 3

Shut down the engine and place the machine in the SERVICE POSITION (refer to page (ii) in the front of this Shop Manual). It is particularly important to install chocks at the front and rear tandem wheels. Ensure that the engine cannot be started. Remove and retain the ignition key. Turn the battery isolation switch to the "OFF" position.

Fig. 4

Release the hand brake. Remove and discard the cotter pin (29). Remove the clevis pin (28). Disconnect the hand brake cable (4) from the operating cam (27).

Fig. 5

Disconnect the hand brake cable (4) from the cable anchor bracket (41). Remove the bolts (39) and lockwashers (40) retaining the cable anchor bracket. Disconnect the cable anchor bracket from the spring (23).

Fig. 6

Remove the shoulder bolts (32). Remove the brake caliper assembly and place on a clean workbench.

Fig. 7

Remove the plug on the lower left hand side of the transmission housing. Drain the oil into a container (capacity: 14 U.S. gal. [11.6 Imp. gal., 53L]). Clean and install the plug.

700 SERIES SHOP MANUAL

HAND BRAKE

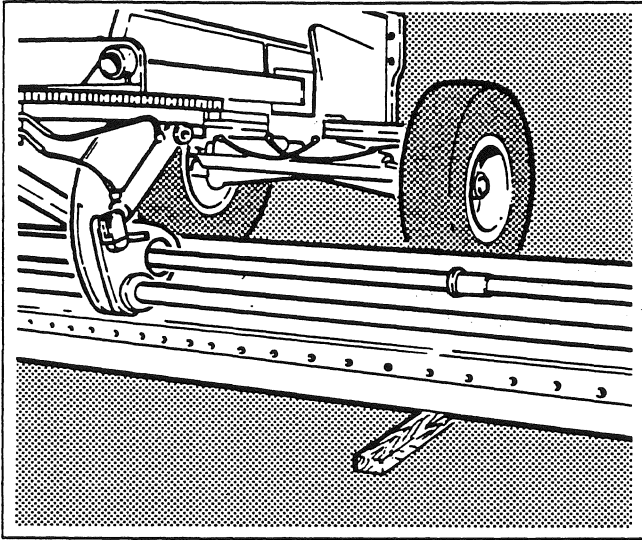

Fig. 2

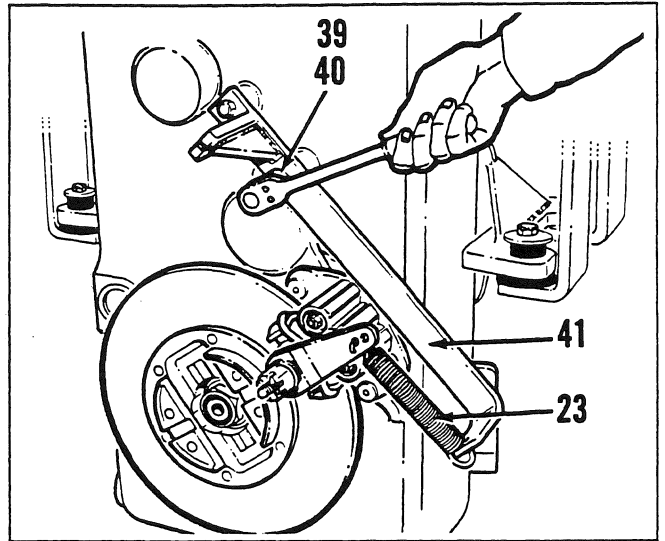

Fig. 5

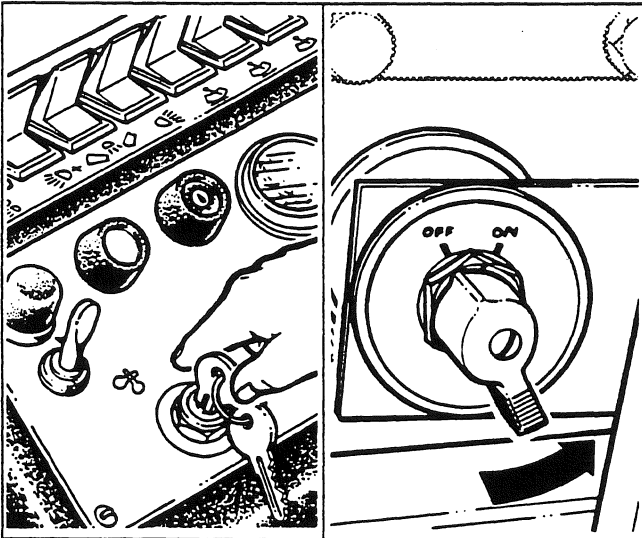

Fig. 3

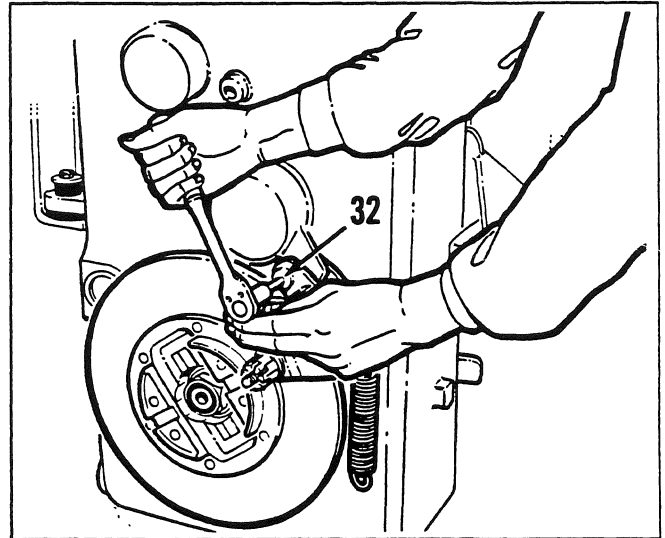

Fig. 6

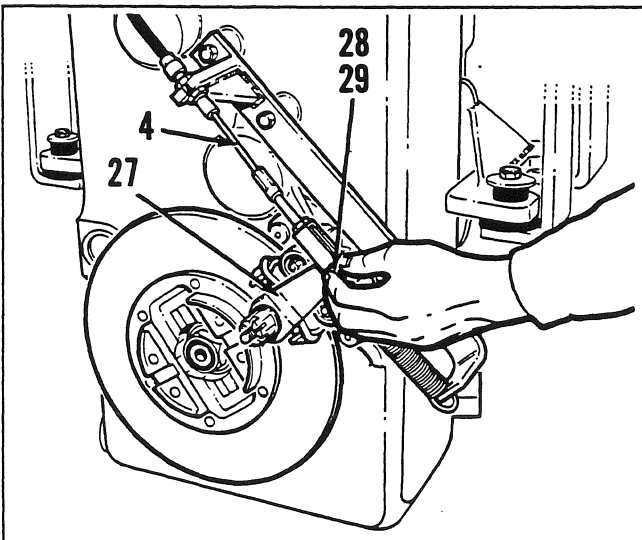

Fig. 4

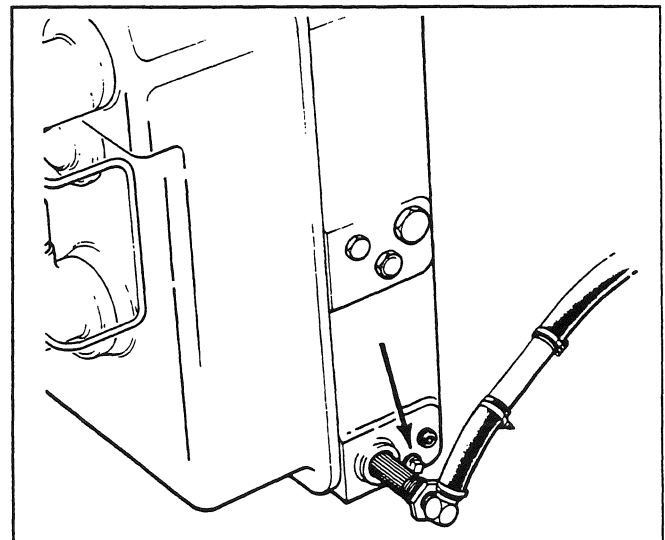

Fig. 7

700 SERIES SHOP MANUAL

HAND BRAKE

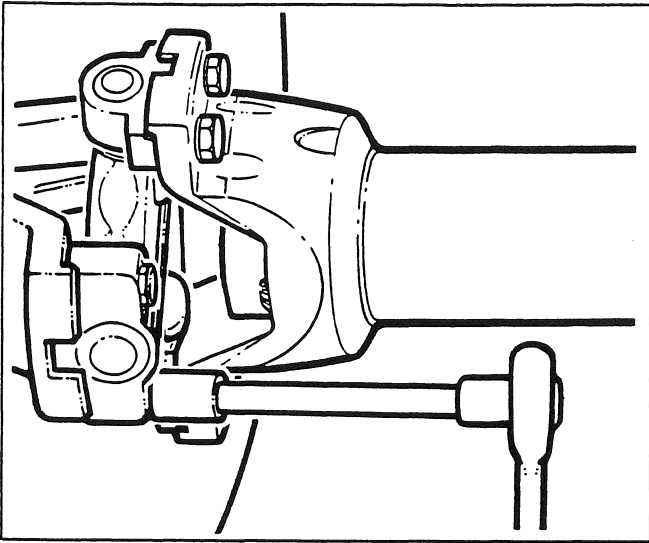

Fig. 8

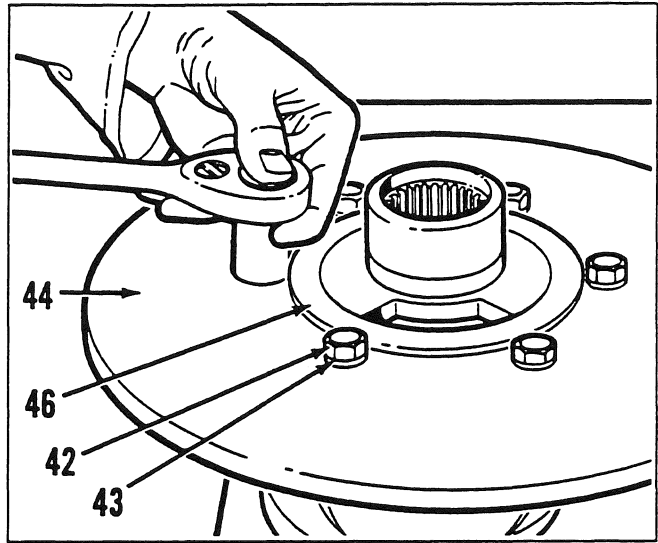

Fig. 11

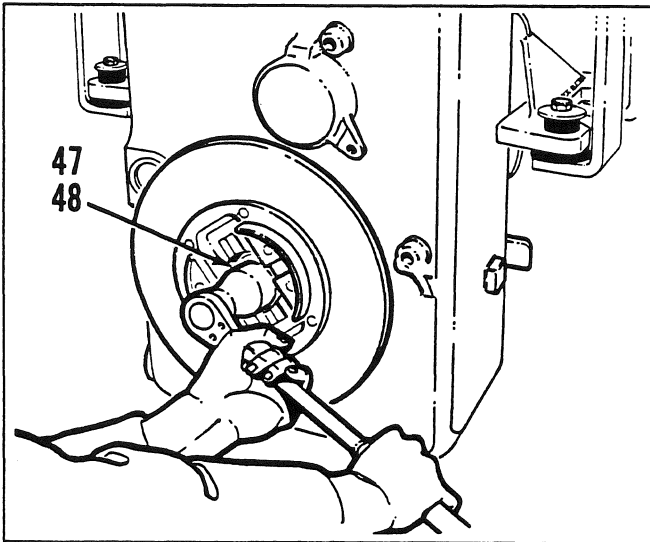

Fig. 9

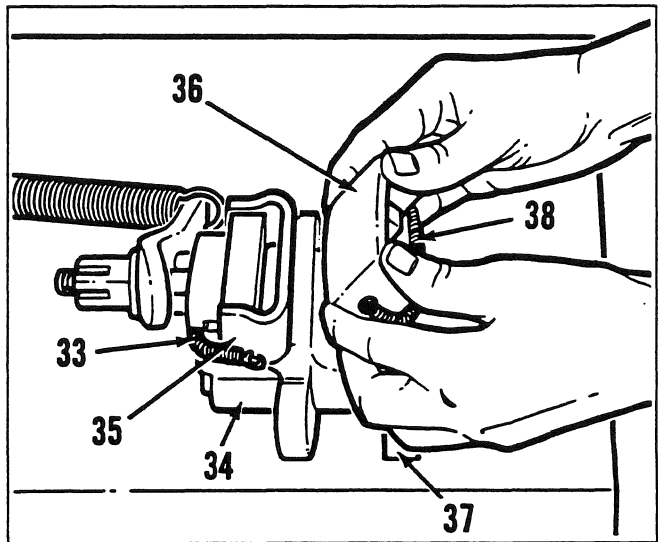

Fig. 12

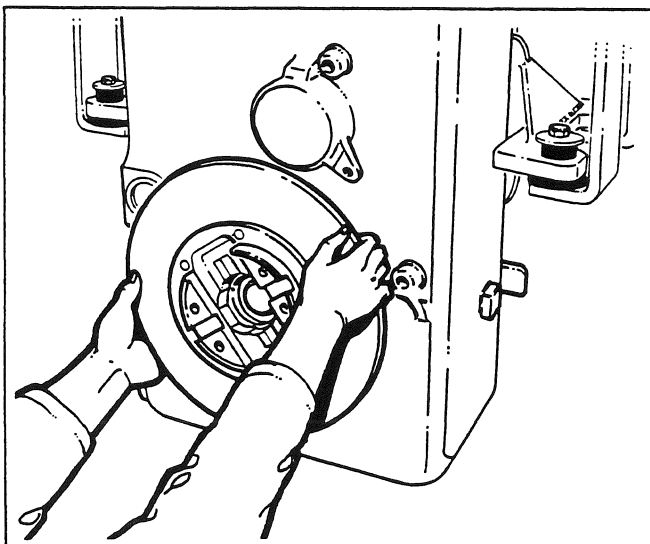

Fig. 10

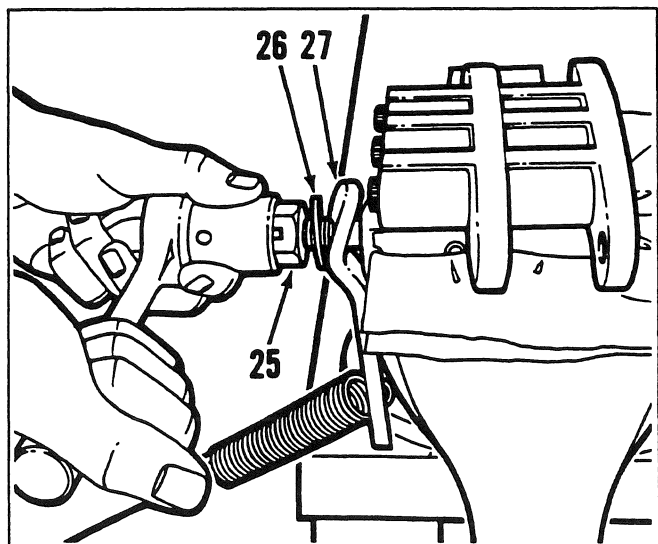

Fig. 13

700 SERIES SHOP MANUAL

HAND BRAKE

Hand Brake - Removal and Disassembly (Continued)

Fig. 8

Disconnect the lower drive shaft at both yokes. Remove the lower drive shaft.

Fig. 11

Clamp the drive shaft flanges of the yoke in a vise with soft jaws. Avoid damaging the disc and oil seal surfaces. Remove the bolts (42) and lockwashers (43) retaining the disc (44) to the yoke (46). Separate the parts.

Fig. 9

Remove the locknut (48) and flatwasher (47) retaining the disc and yoke assembly. Discard the locknut.

Fig. 12

Disconnect the springs (33 and 38). Remove the friction pad holders (35 and 36) from the castings (34 and 37).

Fig. 10



Carefully remove the disc and output yoke assembly. Remove and discard the oil seal (45).

Fig. 13

Clamp the brake caliper assembly in a vise with soft jaws. Remove and discard the cotter pin (24). Remove the castle nut (25), washer (26) and operating cam (27).

700 SERIES SHOP MANUAL

HAND BRAKE

Hand Brake - Removal and Disassembly *(Continued)*

Fig. 14

Remove the two push pins (31) from the casting (34).

Fig. 17

Pry off the release button (18). Remove and discard the handle grip (19).

Fig. 15

Remove the bolts (30) retaining the castings (34 and 37). Separate the castings.

Fig. 18

Remove and discard the spring clip fastener (17). Remove the spacer washers (14 and 16) and spring (15).

Fig. 16

Remove and discard the cotter pin (6). Remove the clevis pin (3), washer (5) and hand brake cable (4) from the handle (13).

Fig. 19

Remove and discard the cotter pin (11). Remove the clevis pin (20), spacer (7) and washers (12 and 22) from the handle (13).

700 SERIES SHOP MANUAL

HAND BRAKE

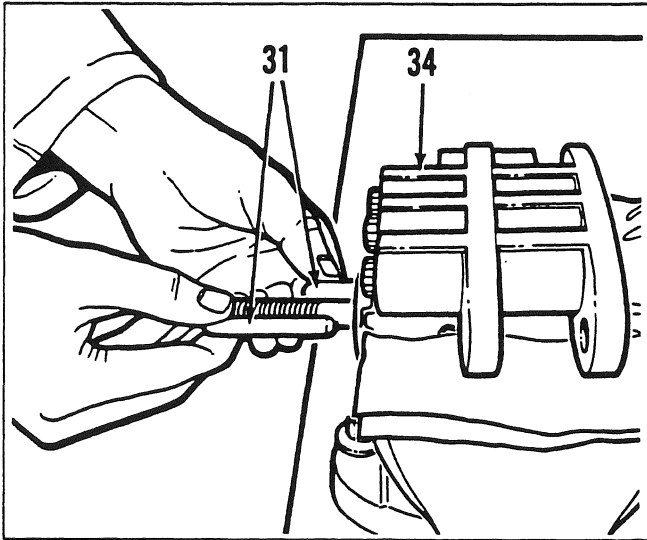

Fig. 14

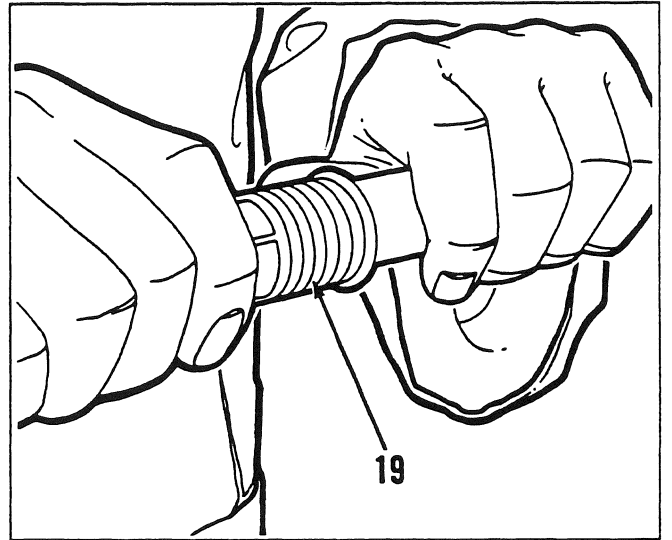

Fig. 17

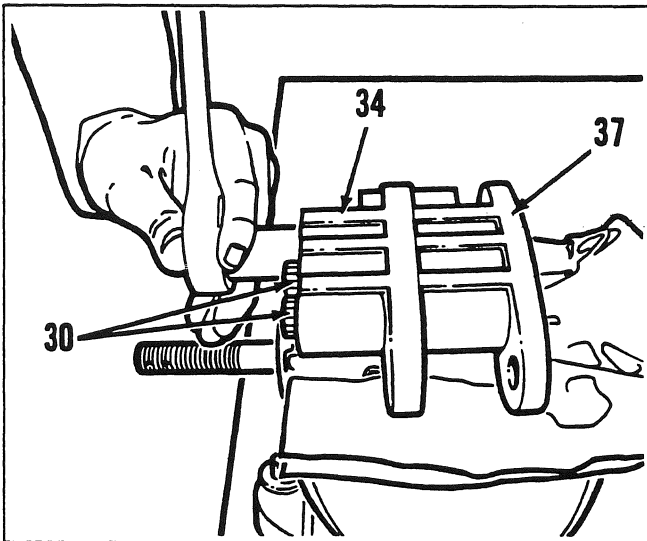

Fig. 15

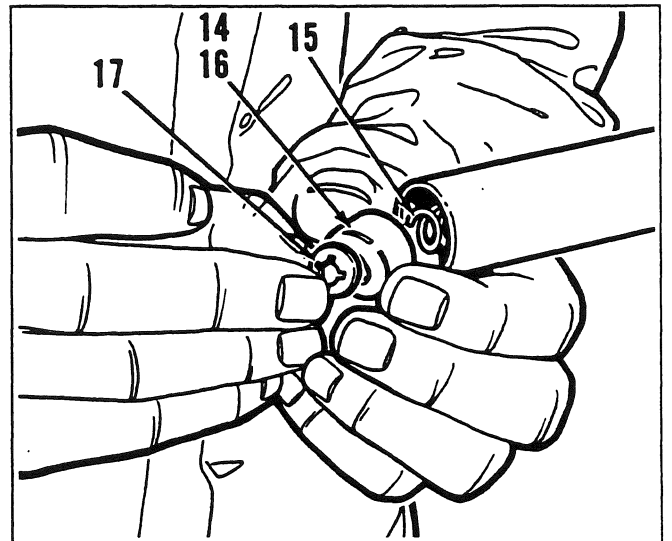

Fig. 18

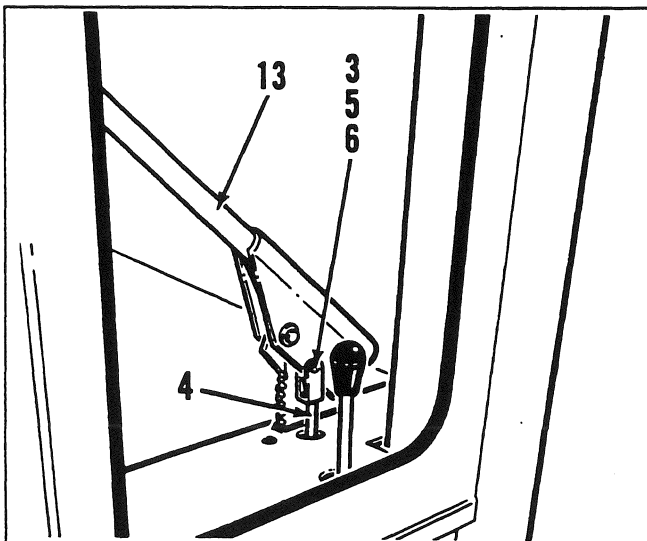

Fig. 16

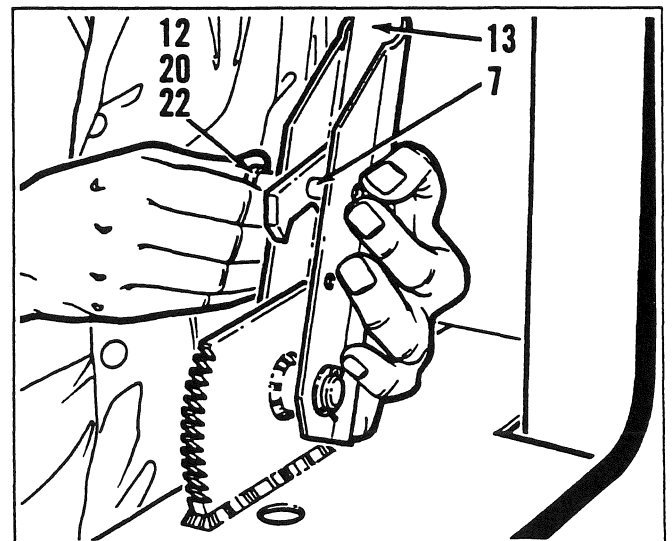

Fig. 19

700 SERIES SHOP MANUAL
HAND BRAKE

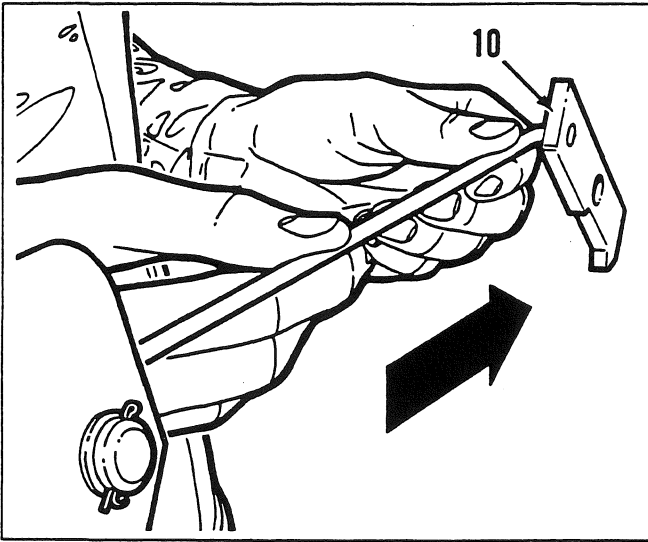

Fig. 20

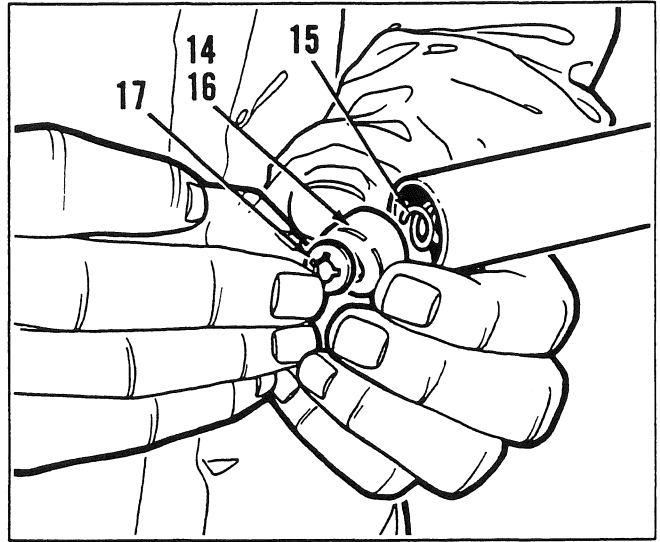

Fig. 23

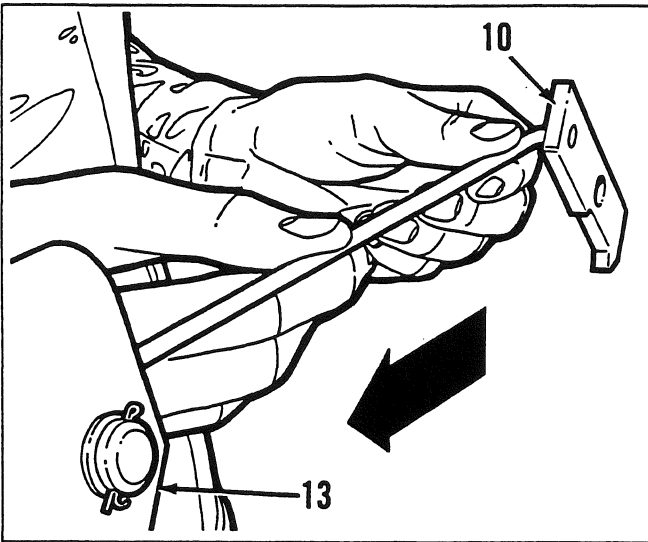

Fig. 21

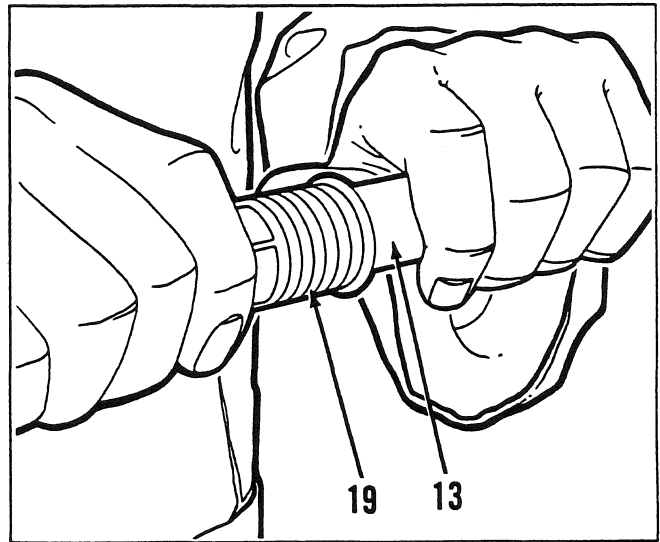

Fig. 24

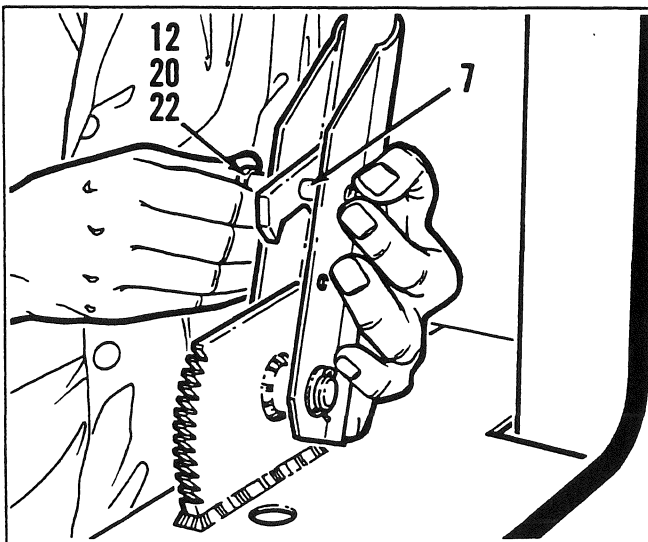

Fig. 22

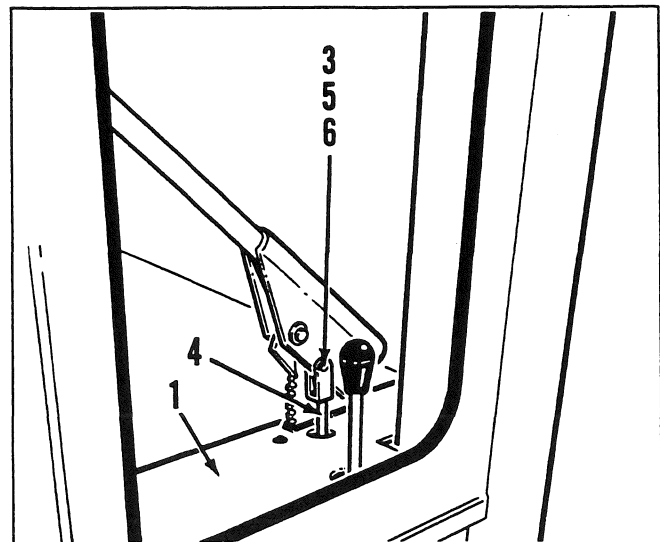

Fig. 25

700 SERIES SHOP MANUAL

HAND BRAKE

Hand Brake - Disassembly *(Continued)*

Fig. 20

Remove the pawl and pawl rod (10). Inspect for signs of wear. Inspect the ratchet (2) attached to the left hand seat deck plate (1) for signs of wear. Replace worn parts.

NOTE: *These parts are critical for holding the brake in the applied position.*

Fig. 23

Install the spacer washer (14), spring (15) and second spacer washer (16). Install a new spring clip fastener (17).

Hand Brake - Assembly and Installation

Fig. 21

Install the pawl and pawl rod (10) into the handle (13).

Fig. 24

Immerse a new handle grip (19) in hot water. When the grip is soft, carefully install on the end of the handle (13). Install the release button (18).

Fig. 22

Install the washers (22), clevis pin (20), spacer (7) and washer (12). Secure the clevis pin with a new cotter pin (11).

Fig. 25

Install the short clevis end of the hand brake cable (4) through the holes in the bracket and left hand seat deck plate (1) until the cable collar abuts the bracket. Install the clevis pin (3) and washer (5) and secure with a new cotter pin (6). Place the handle in the lowest position.

700 SERIES SHOP MANUAL

HAND BRAKE

Hand Brake - Assembly and Installation (Continued)

Fig. 26

Clamp the castings (34 and 37) in a vise with soft jaws and install the bolts (30). Tighten the bolts to the specified torque.

Fig. 29

Lubricate the working surface of the operating cam (27) with graphite spray compound, Champion part number CL 300. Do not allow graphite spray to contact the friction pads or disc. Install the operating cam, washer (26) and castle nut (25). Do not install the cotter pin (24).

Fig. 27

Before installing new friction pad holders (35 and 36), check the code stamped on the back of each pad. The first number of the code must be "5". Carefully install the new pad holders - curved edge toward the castings. Ensure the springs (33 and 38) are properly secured in the casting grooves.

Fig. 30

Clamp the drive shaft flanges of the yoke (46) in a vise with soft jaws. Avoid damaging the disc and oil seal surfaces. Install the disc (44) and retain with the bolts (42) and lockwashers (43). Tighten the bolts in a diagonal sequence to the specified torque. Ensure that the disc is free of oil and grease.

Fig. 28

Lubricate the push pins (31) with graphite spray compound, Champion part number CL 300. Do not allow graphite spray to contact the friction pads or disc. Install the push pins into the casting (34).

Fig. 31

Lubricate and install a new oil seal (45). Lubricate the yoke splines. Apply a bead of gasket eliminator, Champion part number 25303, onto the bearing face of the yoke.

700 SERIES SHOP MANUAL

HAND BRAKE

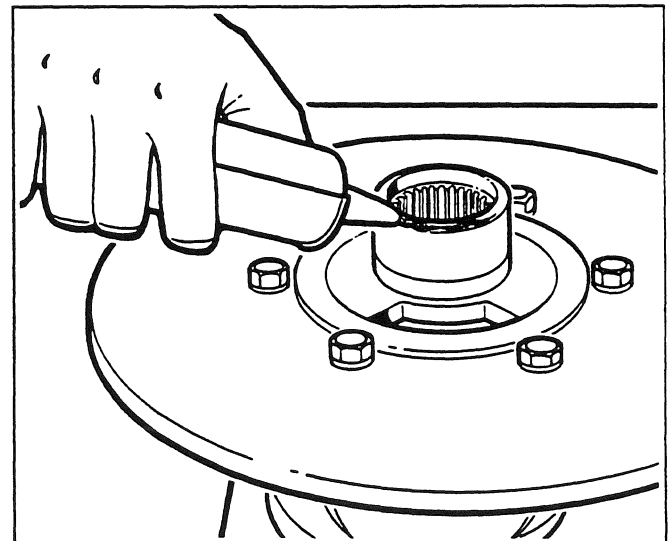
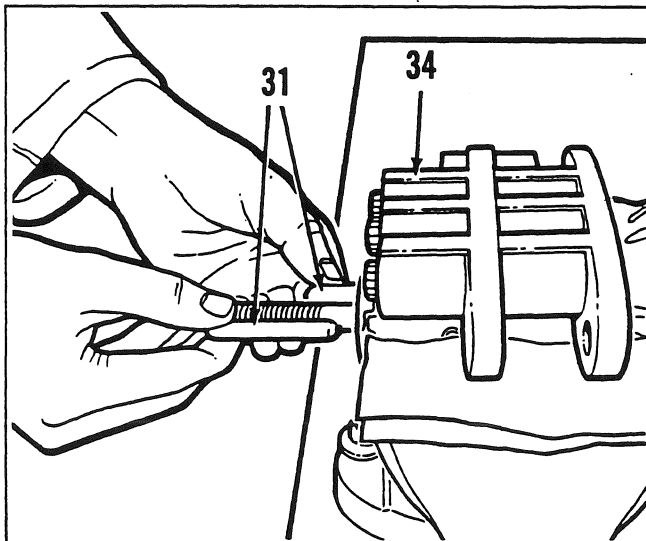
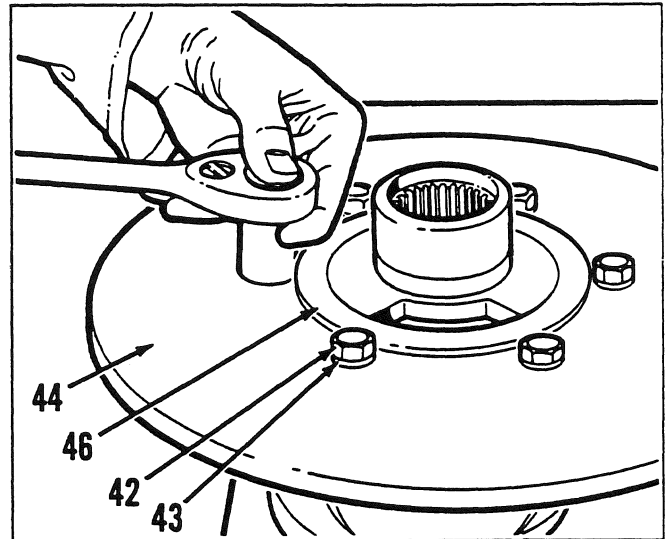
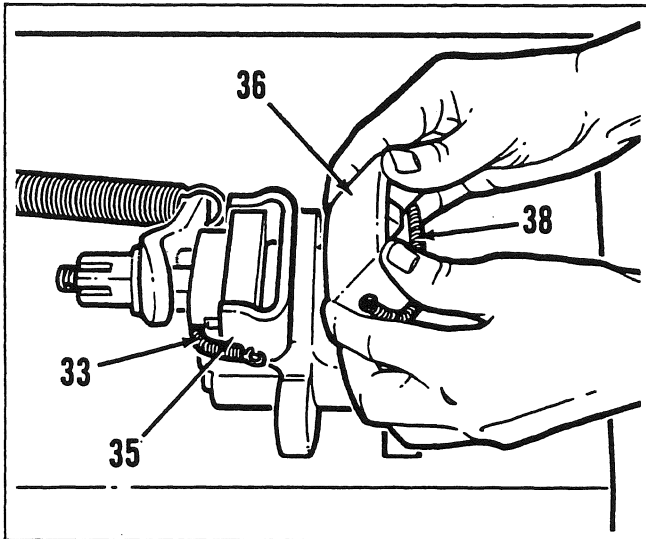
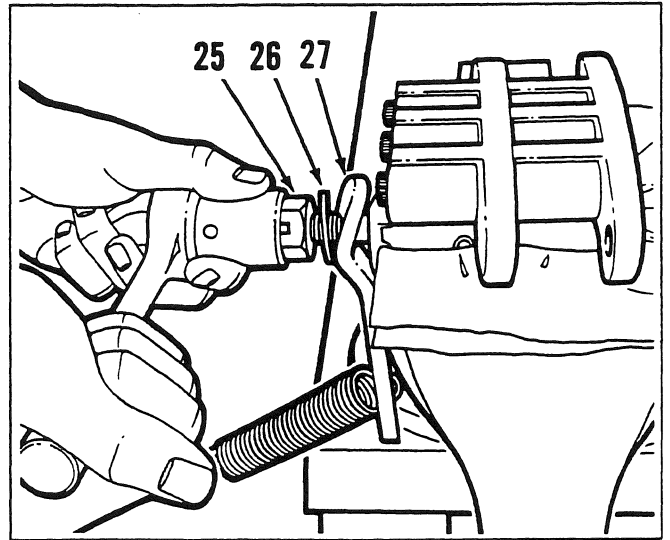
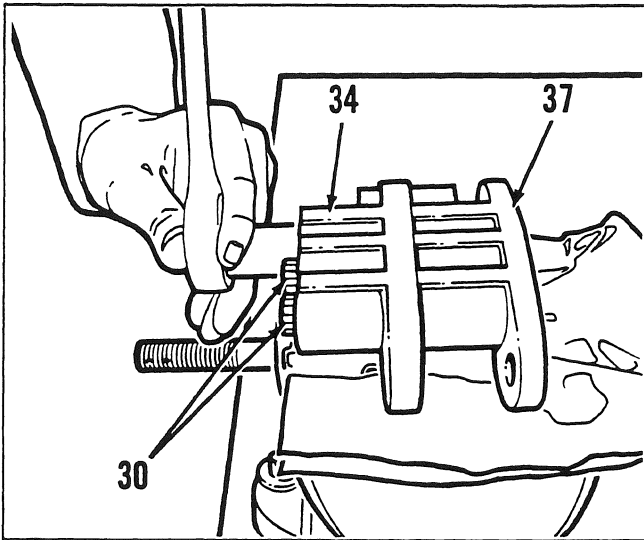

700 SERIES SHOP MANUAL

HAND BRAKE

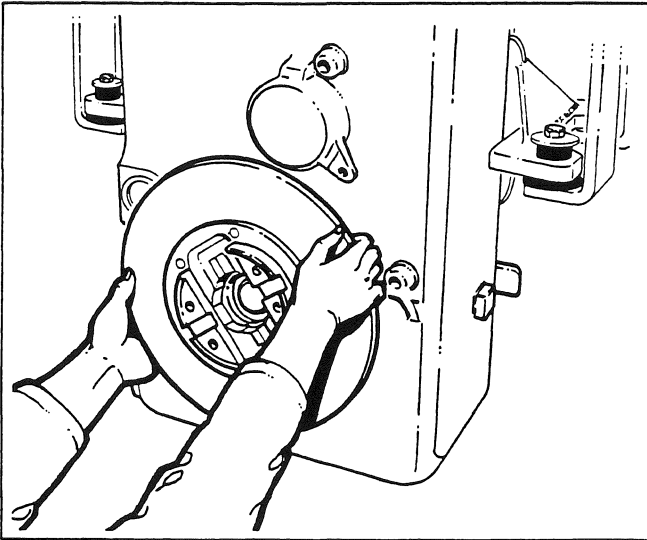

Fig. 32

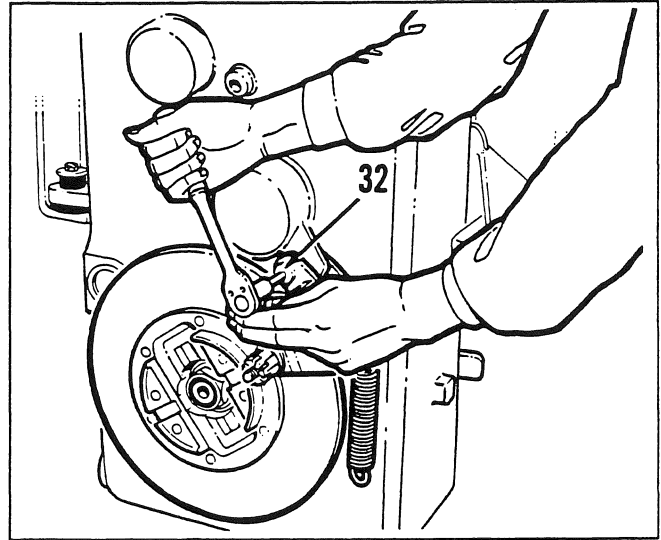

Fig. 35

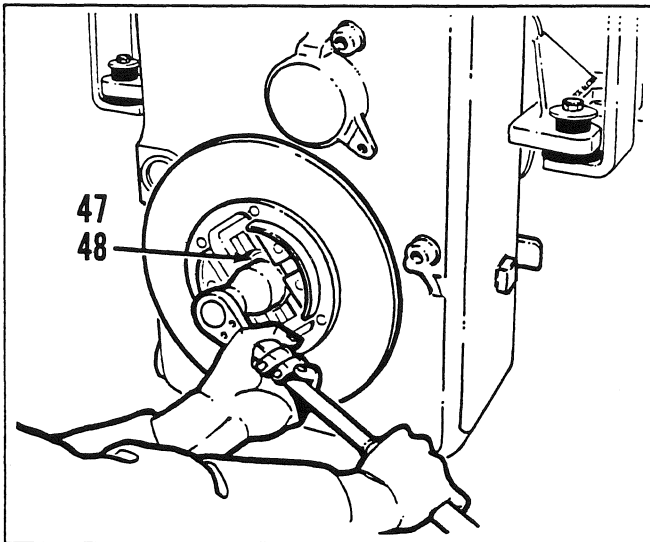

Fig. 33

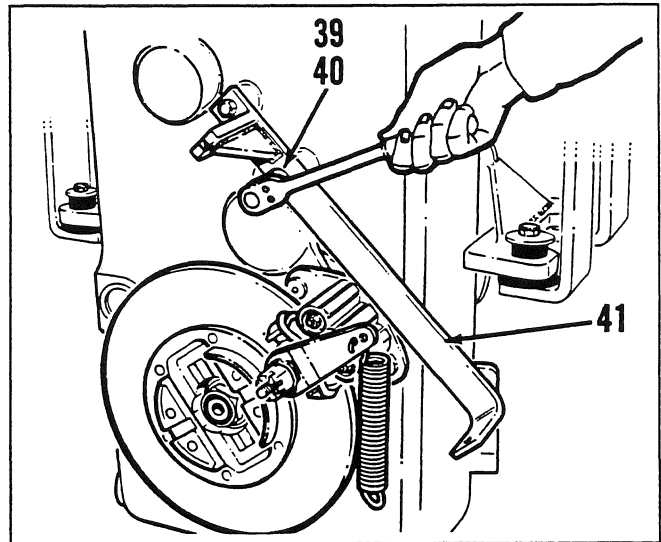

Fig. 36

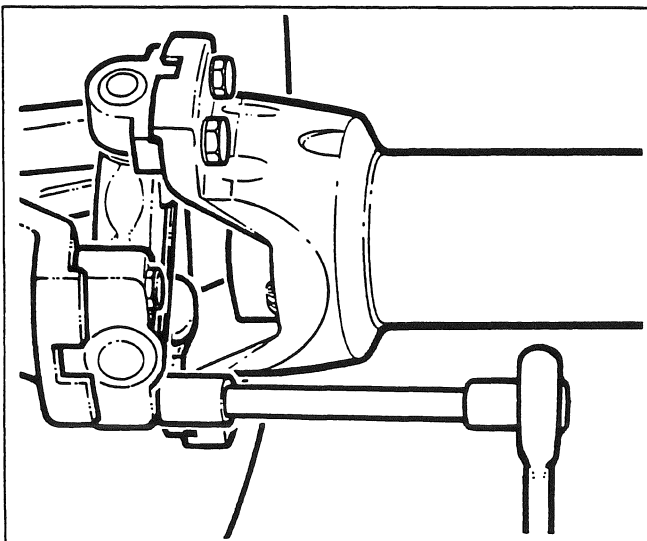

Fig. 34

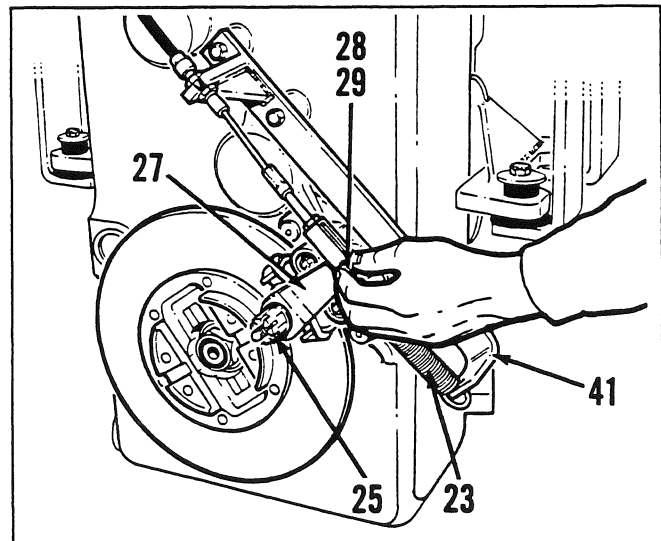

Fig. 37

700 SERIES SHOP MANUAL HAND BRAKE

Hand Brake - Assembly and Installation (Continued)

Fig. 32



Carefully install the disc and yoke assembly onto the transmission output shaft.

Fig. 33

Install the flatwasher (47) and new locknut (48). Tighten the locknut to the specified torque. Remove any greasy marks from the disc.

Fig. 34

Ensure that the mating surfaces are clean and without burrs. Connect the lower drive shaft to both yokes. Tighten the capscrews to the specified torque.

Fig. 35

Apply a light coating of anti-seize compound, Champion part number 30453, onto the shoulder bolts (32). Carefully install the brake caliper assembly onto the transmission case and secure with the shoulder bolts. Tighten the bolts to the specified torque. Check to see if the brake caliper assembly moves freely on the shoulder bolts. If binding occurs, investigate and rectify the problem.

Fig. 36

Install the cable anchor bracket (41) to the transmission case and secure with the bolts (39) and lockwashers (40). Connect the hand brake cable (4) to the cable anchor bracket. Secure the cable nuts at the bracket and clevis to finger tightness only.

Hand Brake - Adjustment and Testing

Fig. 37

Secure the castle nut (25) to finger tightness only while gently rocking the operating cam (27) back and forth to determine the lowest point on the cam. Only the slightest amount of play should exist. Pull the cable at its free end to remove any slack or lost motion. Move the cam in the direction of the cable to cancel any lost motion between the cam and the push pins (31). Adjust the cable clevis to coincide with the outer hole of the cam. Fully tighten all cable nuts. Install the clevis pin (28) and secure with a new cotter pin (29). Connect the spring (23) to the cable anchor bracket (41). Check that the handle locks in all positions. This verifies that the mechanism does not bind. Refill the transmission to the required level with fresh system oil.

700 SERIES SHOP MANUAL

HAND BRAKE

Hand Brake - Adjustment and Testing (Continued)

Fig. 38

NOTE: Adjust the brake cable before adjusting the caliper assembly.

Loosen the castle nut (25) approximately 1-1/2 to 2-1/2 flats. Align one of the castle nut slots with the hole in the caliper assembly threaded rod. The hand brake lever should move five to six ratchet teeth when the brake is properly adjusted. After making the adjustment, install and secure a new cotter pin (24).

Fig. 39

After adjusting, prepare the grader for a brake function test and engine stall test. Make a visual check around the machine. Ensure all personnel are clearly away from the area of the caliper assembly or drive shafts. Start the engine when it is safe to do so. Move the grader to an appropriate test area and drive the machine forward in eighth gear at full engine rpm for one minute. Stop the grader and shut down the engine. Remove and retain the ignition key. Check the hand brake disc for signs of friction pad drag by carefully determining if the disc is hot. If the friction pads are dragging, remove the castle nut cotter pin. Loosen the castle nut by one flat. Replace and secure the cotter pin.

Fig. 40

The friction pads should be properly burnished as follows. Start the engine when it is safe to do so. Drive the machine forward in third gear and lightly apply the hand brake a few seconds at a time to reduce engine speed. Repeat this procedure four or five times until the braking action becomes more aggressive. Stop the grader and place the machine in the SERVICE POSITION.

Fig. 41

Apply the hand brake until the pawl engages the sixth ratchet tooth. Start the engine when it is safe to do so. Adjust the engine speed to low idle. Depress the clutch pedal. Select third speed forward. Slowly release the clutch pedal - taking approximately two seconds to do so. The engine **must** stall. If the engine does not stall, either re-burnish or re-adjust the caliper assembly. Repeat this procedure until the engine can be made to stall, but without the hand brake being adjusted too tight.

Fig. 42

You are recommended to check the hand brake adjustment and operation every day. After 50 hours and at every 500 hours, check for cable stretch. Refer to Fig. 37 for instructions of how to adjust the cable.

NOTE: If you have used the hand brake in an emergency to bring the grader to a stop, you must inspect and adjust the brake caliper assembly before moving the grader.

700 SERIES SHOP MANUAL

HAND BRAKE

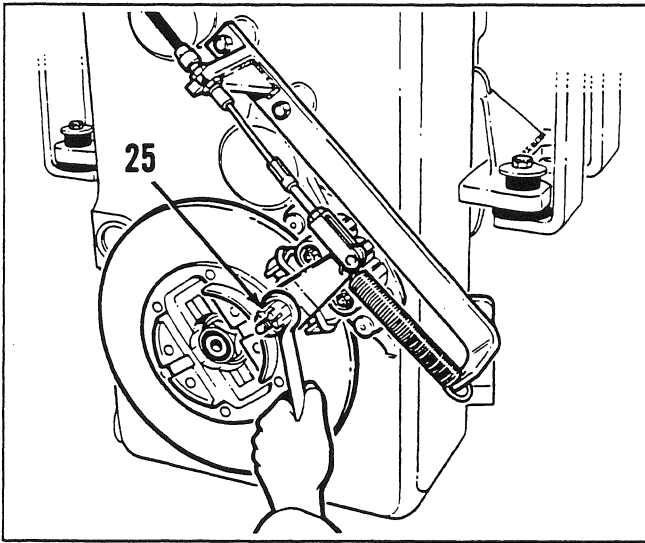

Fig. 38

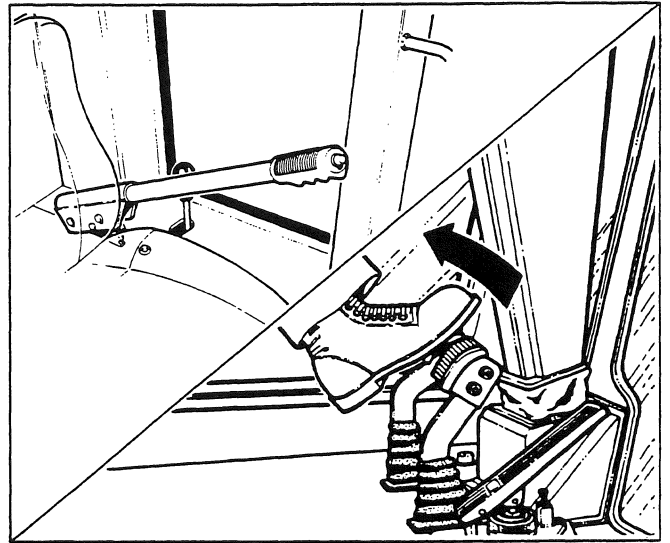

Fig. 41

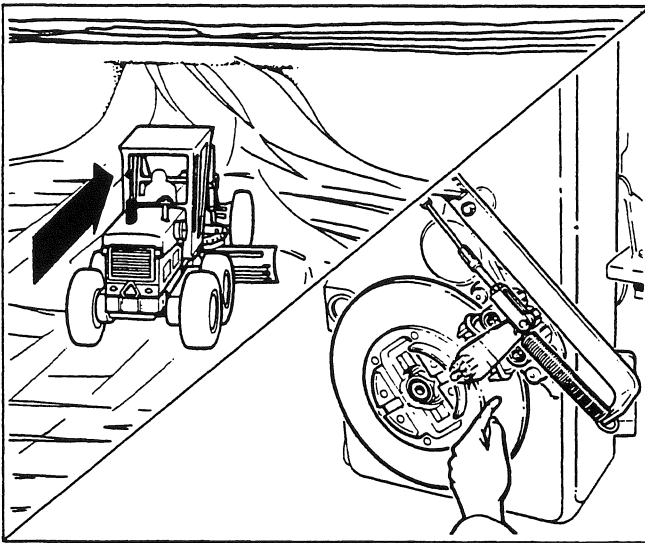

Fig. 39

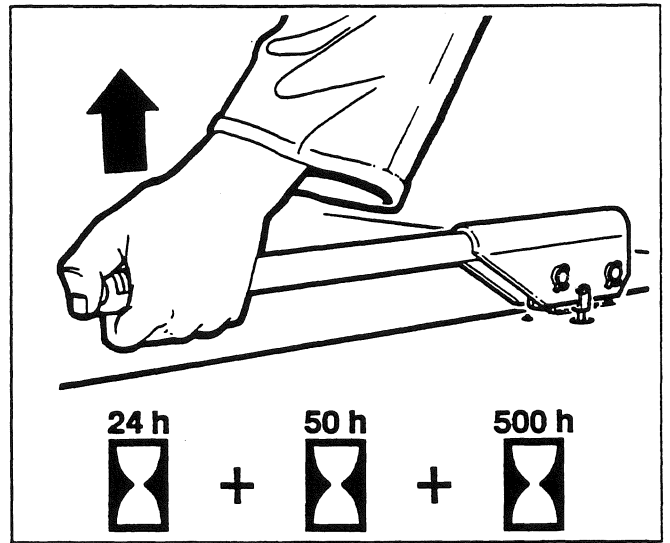

Fig. 42

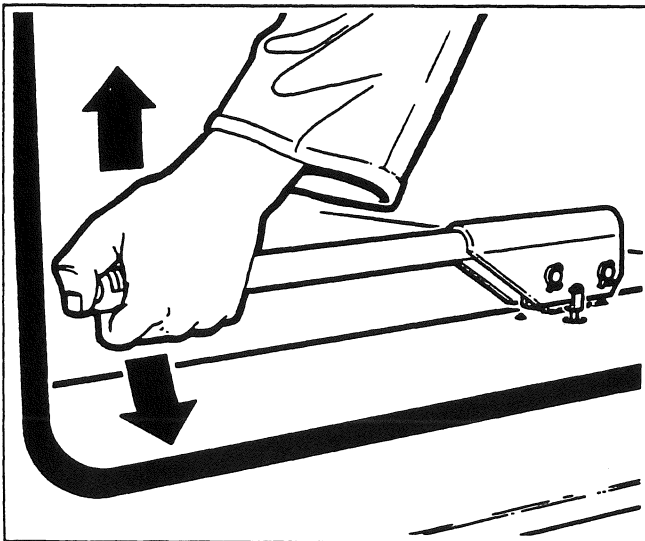

Fig. 40

700 SERIES SHOP MANUAL

HAND BRAKE

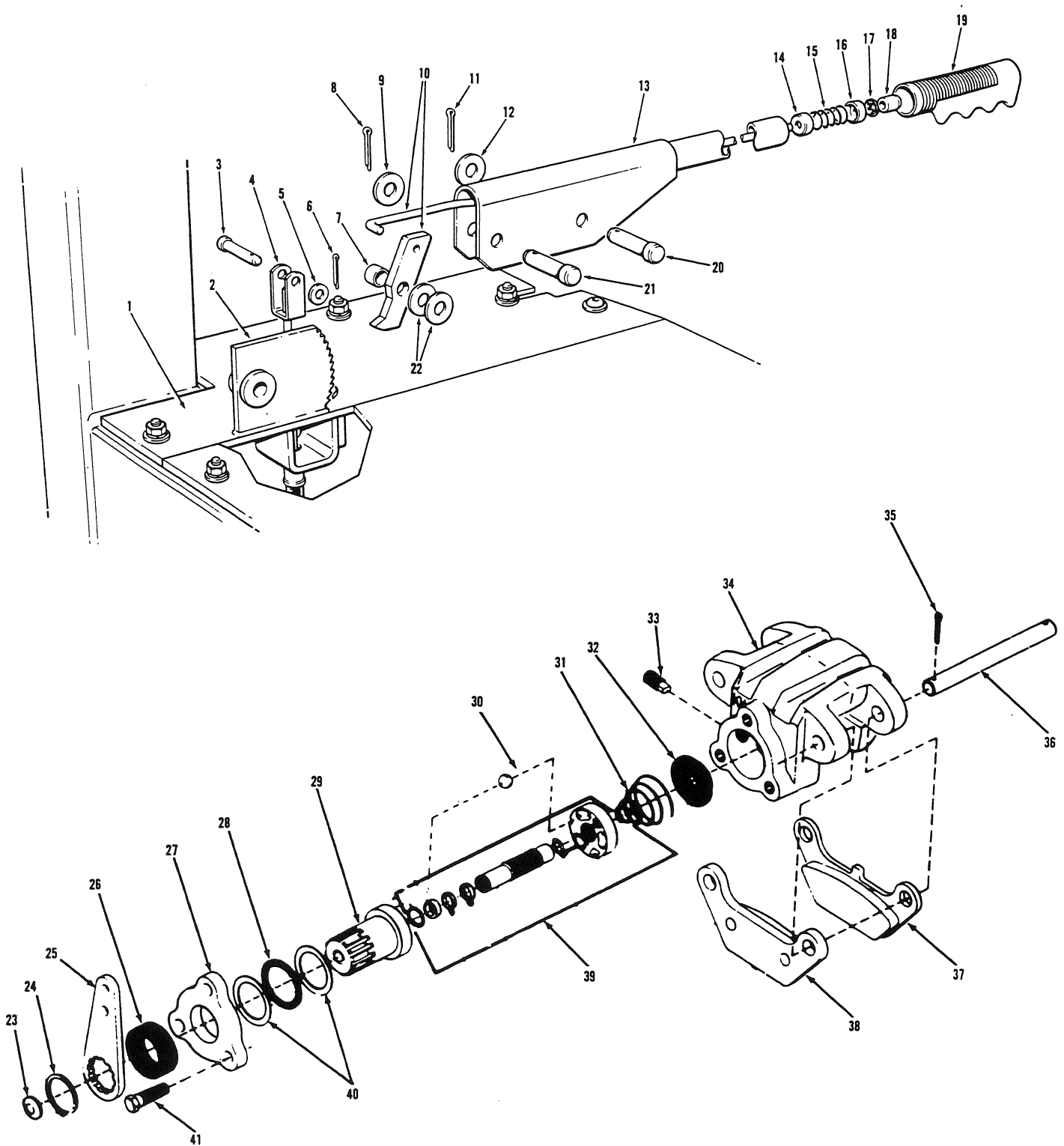

Fig. 43 Models 750 through 780A S/N 21007 and up

700 SERIES SHOP MANUAL

HAND BRAKE

Item	Description	Item	Description	Item	Description
1	Seat deck plate	15	Spring	29	Rotor
2	Ratchet	16	Spacer washer	30	Ball
3	Clevis pin	17	Spring clip fastener	31	Conical return spring
4	Hand brake cable	18	Release button	32	Dust boot
5	Washer	19	Handle grip	33	Anti-rotation key
6	Cotter pin	20	Clevis pin	34	Casting
7	Spacer	21	Clevis pin	35	Cotter pin
8	Cotter pin	22	Washers	36	Mounting pin
9	Washer	23	Plastic plug	37	Pad and holder assembly
10	Pawl and pawl rod	24	Snap ring	38	Pad and holder assembly
11	Cotter pin	25	Operating cam	39	Shaft, spring and stator assembly
12	Washer	26	Seal	40	Thrust washers
13	Handle	27	Cover	41	Bolt
14	Spacer washer	28	Thrust bearing		

Key to Fig. 43 Models 750 through 780A S/N 21007 and up

Description (Models 750 through 780A)

The mechanically actuated, disc type hand brake installed on models 750 through 780A is mounted on the final drive input yoke. Operating the handle in the cab engages and disengages the hand brake caliper assembly.

Generally, this type of hand brake caliper works as outlined in **Description** at the front of this Shop Manual section. The design, however, includes a self-adjusting mechanism which is not part of the caliper assembly installed on models 710 through 740A.

Disassembly (Models 750 through 780A)

1. Disconnect the brake cable and return spring from the operating cam (25).
2. Increase the clearance between the pads and the disc to help remove the caliper assembly. Remove the plastic plug (23). Insert a 1/4 in. Allen wrench into the shaft and turn counter-clockwise to increase the clearance.

3. Support the caliper assembly. Remove and discard the cotter pins (35). Remove the mounting pins (36). Carefully remove the casting (34), together with the pad and holder assemblies (37 and 38). Identify the position of each pad for assembly purposes.
4. Place the casting on a clean workbench. Remove and discard the snap ring (24). Remove the operating cam. Remove and discard the seal (26) from the rotor (29).
5. Remove the bolts (41) and cover (27).
6. Remove the rotor from the casting. Remove the thrust bearing (28) and thrust washers (40).
7. Remove the shaft, spring and stator assembly (39).

NOTE: *Be aware of loose parts. Remove the three balls (30).*

8. Remove the conical return spring (31) from the casting. Remove and discard the dust boot (32).

700 SERIES SHOP MANUAL

HAND BRAKE

9. Remove the anti-rotation key (33) from the casting. Place the parts to one side for cleaning and inspection.

Cleaning and Inspection (Models 750 through 780A)

Clean parts with denatured alcohol. Dry the parts using moisture-free compressed air or lint-free rags.

NOTE: Do not clean the pad and holder assemblies.

A careful and thorough inspection of all parts is extremely important. Check the brake disc surface condition. Replace the disc if it is badly warped or pitted. The disc should run true to within 0.010 in. (0,25 mm). Check friction pad wear. If the pads are worn to less than 3/32 in. (2 mm), replace them. Always replace both pads at the same time.

Examine all parts carefully for signs of excessive wear, damage or corrosion. Check the rotor and stator for cracks. Inspect the thrust bearing for wear. Discard broken springs. Check anti-rotation key for wear or damage. Replace defective parts.

Inspect casting bore for scoring, pitting or corrosion. Replace corroded or deeply scored castings. Use crocus cloth to remove light scores and stains.

Individual parts of the shaft, spring and stator assembly are not available separately. Replace the assembly as a complete unit.

Bench check the self-adjusting mechanism for proper operation. Hold the shaft, spring and stator assembly in one hand and the rotor in the other, allowing a space where the balls would be. Holding the stator stationary, turn the rotor counter-clockwise. The shaft should remain stationary. Turn the rotor back to its original position. The shaft should turn out of the stator. This is a test to check the clutch spring and anti-rotation spring for proper grab and slip torque. Replace the shaft, spring and stator assembly if it fails this test.

Assembly (Models 750 through 780A)

1. Install the anti-rotation key (33) into the casting (34). Install the anti-rotation key until the end of the key is approximately 2 in. (5 cm) from the opposite surface of the bore. Retract the key up to one half turn to align the flats parallel to the bore.
2. Apply a coating of molybdenum disulfide grease to the entire bore of the casting.
3. Lubricate and install a new dust boot (32) into the casting bore. Ensure the boot seats properly and is not ripped or torn. Install the conical return spring (31).
4. Apply a coating of molybdenum disulfide grease to the shaft, spring and stator assembly (39), including the keyway and ball pockets. Install the assembly into the casting bore. Install the three balls (30) into the ball pockets.
5. Apply a coating of molybdenum disulfide grease to the shank and ball pockets of the rotor (29). Install the rotor into the casting bore.
6. Apply a coating of molybdenum disulfide grease to the thrust bearing (28) and thrust washers (40). Install the thrust bearing and thrust washers onto the rotor shank.
7. Install the cover (27) and secure with the bolts (41). Torque-tighten the bolts to 70 - 80 lbf.ft (95 - 108 N.m; 9,7 - 11,0 kgf.m).
8. Lubricate and install a new seal (26) over the rotor shank.
9. Install the operating cam (25) and secure with a new snap ring (24).
10. If you are installing the existing pad and holder assemblies (37 and 38), check the identification to ensure correct positioning during installation. If you are installing new pad and holder assemblies, check the numeric code stamped on the ear or on the back of the pad. The first number(s) specifies the type of friction material. Check to see that the new pads have the same friction material type number as the old pads.

700 SERIES SHOP MANUAL

HAND BRAKE

11. Place the casting and pad and holder assemblies into position at the bracket. Install the mounting pins (36) and secure with new cotter pins (35).
12. Check to see if the operating cam is positioned as shown in Fig. 44. If not, remove the snap ring and reposition the operating cam. Install the snap ring.

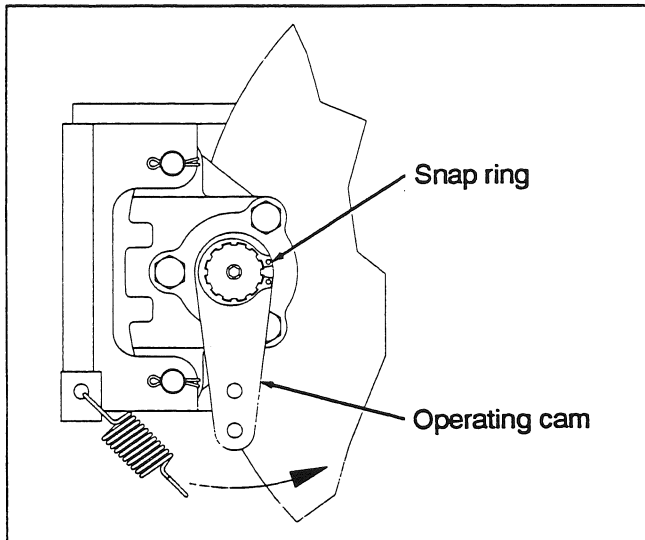

Fig. 44

13. Insert a 1/4 in. Allen wrench into the shaft and turn counter-clockwise until there is a 0.030 in. (0,8 mm) gap between the applying pad and disc (see Fig. 45). Install the plastic plug (23).

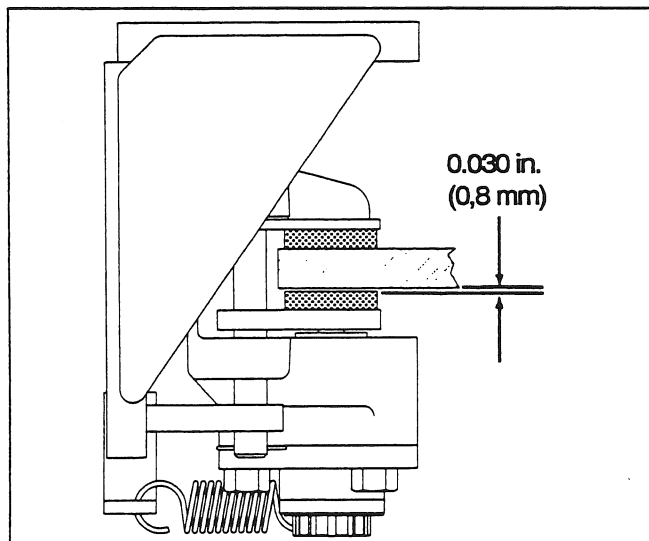

Fig. 45

14. Install and adjust the hand brake cable (4) as described in the following instructions.

Installing and Adjusting Hand Brake Cable (Models 750 through 780A)

1. Move the operating cam counter-clockwise. Only a slight amount of movement should exist.
2. Pull the cable at its free end to remove any slack or lost motion.
3. Adjust the cable clevis to coincide with the outer hole of the operating cam. Fully tighten all cable nuts. Install the clevis pin and secure with a new cotter pin. Install the operating cam return spring.
4. Check that the handle (13) locks in all positions. This verifies that the mechanism does not bind.

Hand Brake Function Test (Models 750 through 780A)

1. After checking the friction pad clearance and adjusting the brake cable, prepare the grader for a brake function test and engine stall test.
2. Make a visual check around the machine. Ensure all personnel are clearly away from the area of the caliper assembly and drive shafts. Signal your intention to start the engine. Start the engine when it is safe to do so.
3. Move the grader to an appropriate test area and drive the machine forward in eighth gear at full engine rpm for one minute. Stop the grader and shut down the engine. Remove and retain the ignition key.
4. Check the hand brake disc for signs of friction pad drag by carefully determining if the disc is hot.
5. If the friction pads are dragging, check the gap between the pads and disc. To adjust the gap, remove the plastic plug. Insert a 1/4 in. Allen wrench into the end of the shaft and turn counter-clockwise until there is a 0.030 in. (0,8 mm) gap between the applying brake pad and disc (see Fig. 45). Install the plastic plug.

700 SERIES SHOP MANUAL

HAND BRAKE

Burnishing Friction Pads (Models 750 through 780A)

1. New friction pads, or pads showing signs of high temperature wear (as in an emergency stop), should be properly burnished as follows.
2. Start the engine when it is safe to do so. Drive the machine forward in third gear and lightly apply the hand brake a few seconds at a time to reduce the engine speed (see Fig. 46).

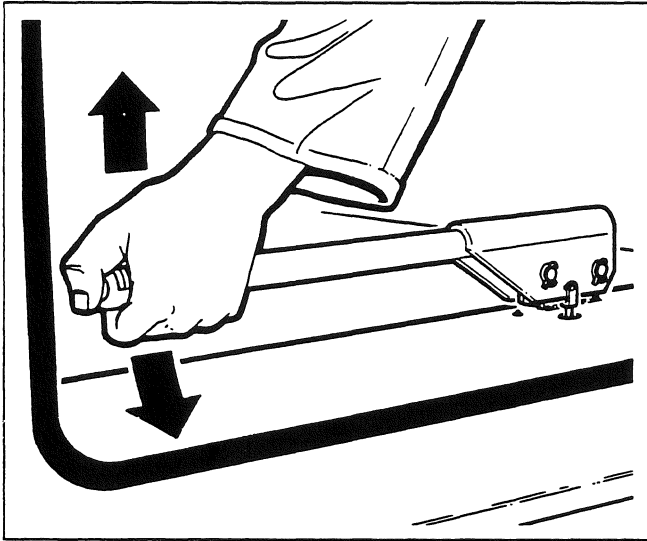

Fig. 46

3. Repeat this procedure four or five times until the braking action becomes more aggressive. Stop the grader and shut down the engine.

Engine Stall Test (Models 750 through 780A)

1. Apply the hand brake until the pawl engages the sixth ratchet tooth.
2. Start the engine when it is safe to do so. Adjust the engine speed to low idle.
3. Depress the clutch pedal. Select third speed forward.
4. Slowly release the clutch pedal - taking approximately two seconds to do so (see Fig. 47). The engine must stall. If the engine does not stall, either re-burnish the friction pads or re-adjust the gap between the applying pad and disc.

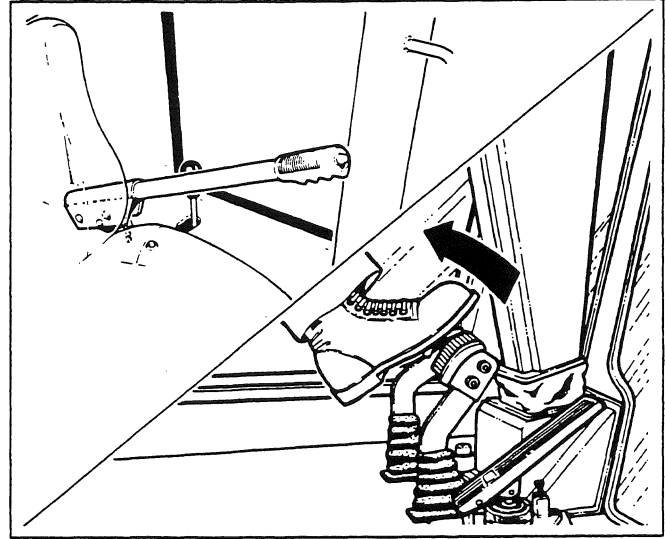

Fig. 47

5. Repeat this procedure until the engine can be made to stall, but without the hand brake being adjusted too tight.